

- 1 cylinder
- 505 cm<sup>3</sup>
- 8,8 kW/12,0 HP
- 3600 r.p.m.
- Nm 30,0@2000

## Available homologation

- ECE R 24 (3.000 r.p.m.) ▲

## Construction

- 4-stroke air cooled diesel engine.
- Conical power take-off on crankshaft.
- Anticlockwise rotation.
- Direct injection.
- Forced lubrication with oil pump.
- Centrifugal speed governor.
- Internal full flow oil filter.
- Oil breathing blow-by with safety device.
- Automatic extra fuel starting device.
- Self bleeding fuel system.
- Torque regulator.
- Manual compression release.
- Die-cast aluminium crankcase.
- Re-borable independent cast-iron cylinders.
- Aluminium alloy cylinder head.
- Built-in rigid feet.
- 3 years warranty.



## Applications

- Two-wheel tractor
- Agricultural mower
- Agricultural pump
- High pressure cleaner
- Generating set
- Vibrating plate

### Specifications

Cylinders	N.	1
Displacement	cm <sup>3</sup>	505
Bore	mm	87
Stroke	mm	85
Compression ratio		19:1
Rating kW/HP	N (80/1269/CEE) ISO 1585	8,8/12,0
	NB ISO 3046 IFN	8,2/11,1
	NA ISO 3046 ICXN	7,5/10,2
Max. torque	Nm	30,0@2200
Min. idling speed		1200
Fuel tank capacity	l	5
Oil consumption	kg/h.	0,0055
Oil sump capacity	l	1,5
Min. allowable oil pressure	bar	0,8
Max. allowable inclination for:		
- short periods of operation (max. time 30 minutes)		25°
- peak values (max. time 1 minute)		35°
Cap. of air required for correct combustion @ 3600 r.p.m.	l/min.	800
Cap. of air required for correct cooling @ 3600 r.p.m.	l/min.	8700
Dry weight	kg	48
Recommended battery	V/Ah	12/50

Minimum pulley diameters for belt drive

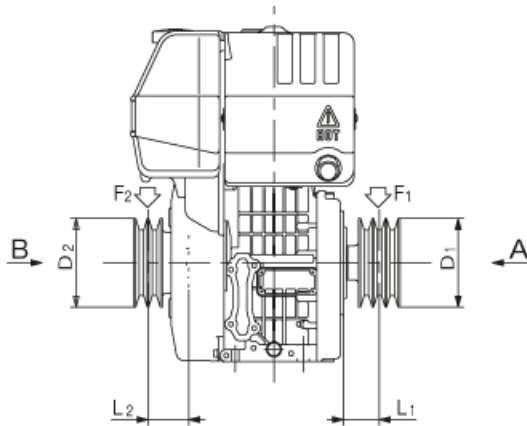

$$D_2 \text{ (mm)} \geq 900 [48 + L_2 \text{ (mm)}] \frac{N \text{ (kW)}}{n \text{ (RPM)}}$$

$$D_1 \text{ (mm)} \geq 570 [55 + L_1 \text{ (mm)}] \frac{N \text{ (kW)}}{n \text{ (RPM)}}$$

Max. intermittent axial load in both directions A-B = 200 kg

$$F_2 \text{ (N)} \leq \frac{64000}{48 + L_2 \text{ (mm)}}$$

$$F_1 \text{ (N)} \leq \frac{100520}{55 + L_1 \text{ (mm)}}$$

Maximum radial force on pulley for belt drive



### Sound pressure level dB (A)

Sound level polar diagram open field - 7 meters microphone - no load running engine.

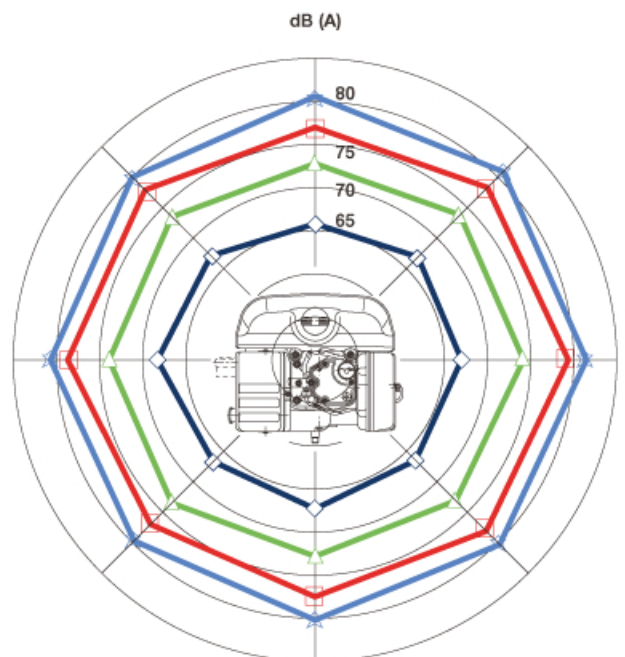

1100 RPM      2000 RPM      3000 RPM      3600 RPM

## Curves KD500 ▲

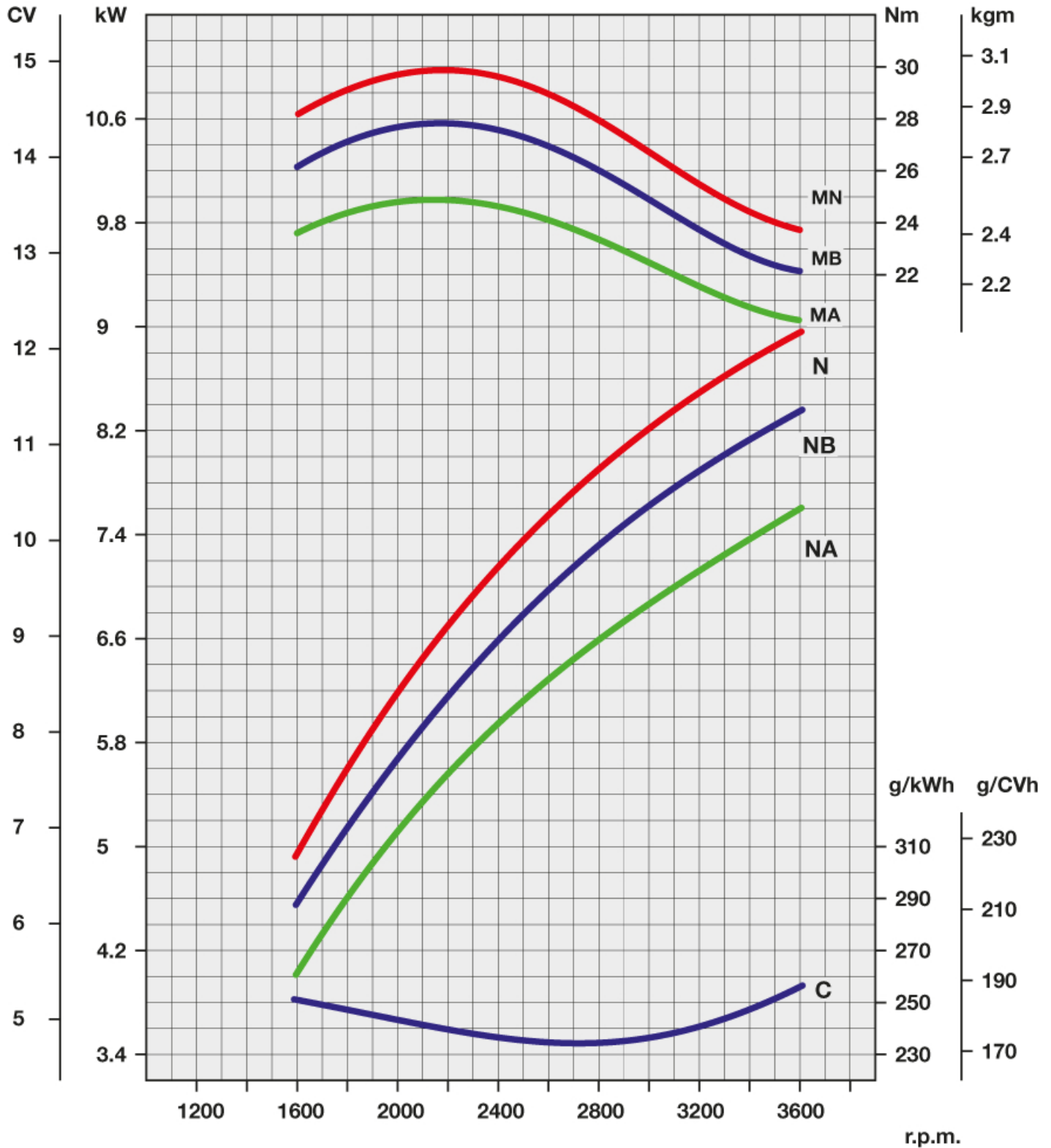

**N** Power curve - 80/1269/CEE - ISO 1585 -

**NB** Power curve - ISO 3046 - IFN -

**NA** Power curve - ISO 3046 - ICXN -

**MN** Torque curve - (N curve)

**MB** (NB curve) - **MA** (NA curve)

**C** Specific fuel consumption - (NB curve)

Power ratings refer to engines equipped with air filter, standard muffler, after being run in and in ambient conditions of 20°C and 1 bar. Power levels drop by 1% every 100m altitude and by 2% every 5°C above 20°C.

### Technical drawings

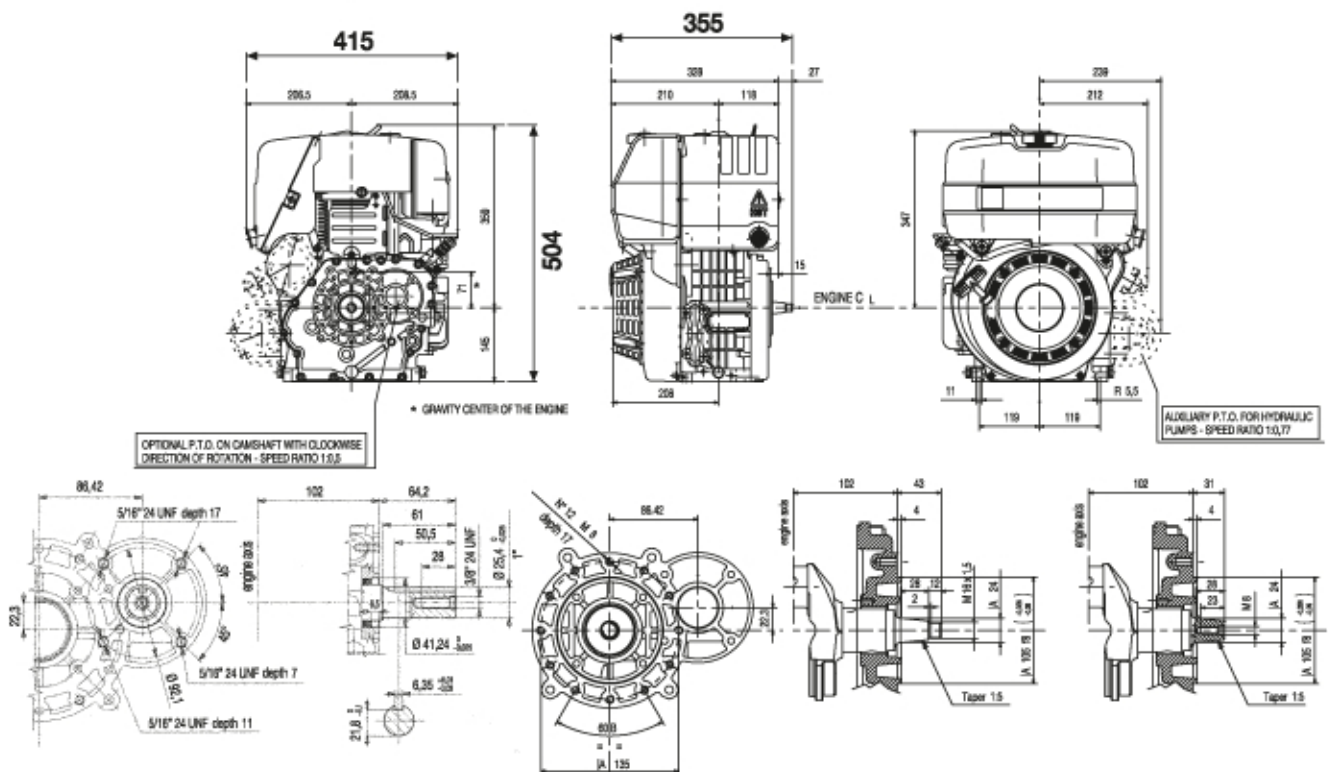

#### Standard equipment

- Accelerator and stop with double linkage for remote control
- Recoil starting
- Automatic deaeration on injection pump
- Dry air filter
- Net oil filter
- Exhaust muffler
- Conical power take-off
- Fuel tank with external fuel filter
- Automatic mechanical fuel supplement
- Parts in natural aluminium
- Zinc plated nuts and bolts
- Black paint on sheet metal parts
- Instruction booklet

#### Special accessories

- Power take-off on flywheel side (engines with electrical starting)
- Power take-off with flanging and special shafts
- Power take-off on camshaft
- Lateral power take off
- Internal dynamic balancer
- Oil bath air cleaner
- Electric starting
- Key switch panel
- Emergency stop through electro-valve
- Accelerator and stop remote control (key start panel with shutdown device)
- Panel protection
- Fuel feed pump
- Oil pressure switch
- Oil temperature switch
- Glow plug on intake manifold
- Recoil with low-noise cover
- Grass protection for engine cooling



LOMBARDINI S.r.l. a Socio unico  
 Cap. Soc. € 44.000.000,00 int. ver. R.E.A. 227083  
 Reg. Imp. RE/CEE Code/P.IVA (IT) 01829970357  
 Via Cav. del Lavoro Adelmo Lombardini, 2  
 42124 Reggio Emilia - Italia  
 Tel. +39.0522.3891 - Fax +39.0522.389503  
 info@lombardini.it [www.lombardini.it](http://www.lombardini.it)



KOHLER RESERVES THE RIGHT TO MAKE MODIFICATIONS WITHOUT PRIOR NOTICE

3558386 - 01-2011

#### KOHLER LOMBARDINI ASIA PACIFIC

26B Keong Saik Road - 089133 Singapore  
 Tel. +65-6225-0556 - Fax +65-6225-0551