

THE NEW
KOHLER® Courage® XT-Series

XT-6, XT-7 and XTR-7 Engines



KOHLER®

KOHLER®

PERFORMANCE
ENGINEERING

Every part, every component, every system on our engines is guided by our exclusive Performance Engineering standards. Take our innovative Smart-Choke™ technology. Available on Courage® XT-Series engines, Smart-Choke requires no priming, and therefore eliminates the risk of flooding the engine. Just pull the starter recoil – or for electric-start engines, simply turn the key – and you're up and running. That's because KOHLER Smart-Choke automatically adjusts the amount of fuel needed to start the engine. It's features like our Smart-Choke that sets us apart, and another reason why you can depend on the worldwide KOHLER® reputation for excellence.



Made the only way we know. Commercial-grade.

Everything you've come to expect from KOHLER® engines for over 75 years – now available for the walk-behind market. From their cast iron cylinder liner to their heavy-duty forged crankshaft, the new Courage® XT-Series engines are tough, reliable and commercial-grade. But while the engines work hard, the consumer doesn't – thanks to a long list of operator features including smooth, ball bearing starts and wide-opening gas fill.



Overhead Valve Design.

Super-efficient combustion for smooth, powerful performance with lower fuel consumption and cleaner emissions.

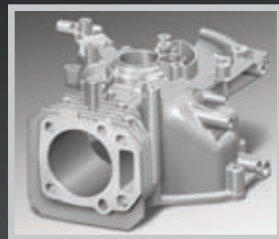

Commercial-Grade Cast Iron Cylinder Liner.

For extra durability and longer engine life. And while others make cast iron liners optional, we make them standard.



Heavy-Duty Forged Crankshaft.

Forged – not cast – for superior tensile strength and less chance for failure. Made tougher for heavy loads and extra-rough mowing conditions.



Flywheel Ball Bearing.

Reduced friction and pulling effort for fast, smooth, easy starts and provides extra lubrication for mowing at all angles.



Wide Gas Tank Opening.

Easier filling, less spilling. And simple, easy-to-see fuel-level checks for the consumer. Another KOHLER exclusive.

Emissions:

Certified for both EPA and California emissions standards. Precise air-to-fuel ratio for cleaner combustion with optimum horsepower and torque.

Service:

Backed by more than 13,000 dealers and distributors worldwide.

Warranty:

Two-year limited warranty covering all consumer applications.

XT-6

3.5 Net hp vertical-shaft engines

KOHLER® COURAGE® ENGINE ARCHITECTURE

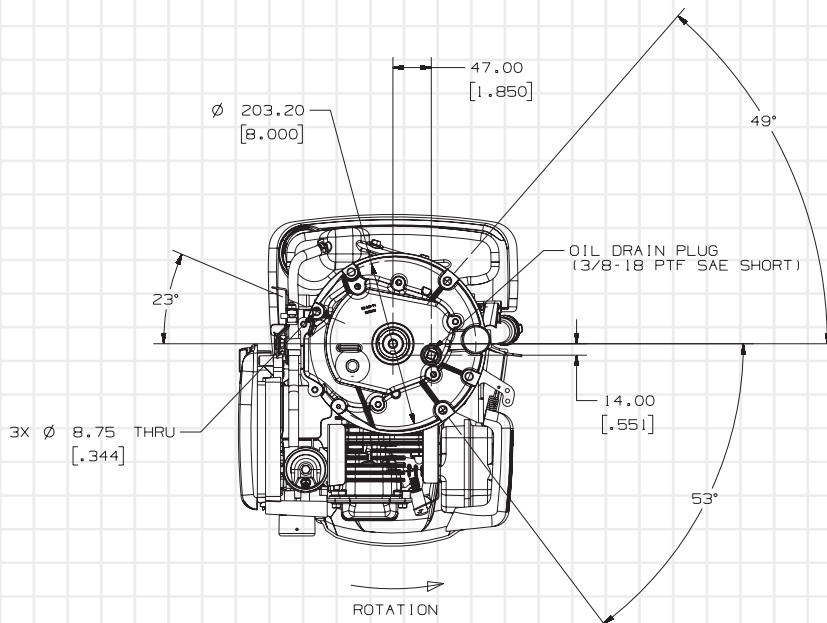
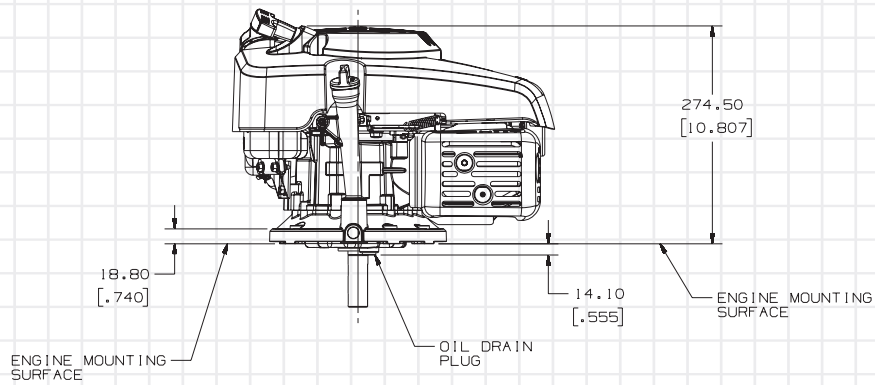
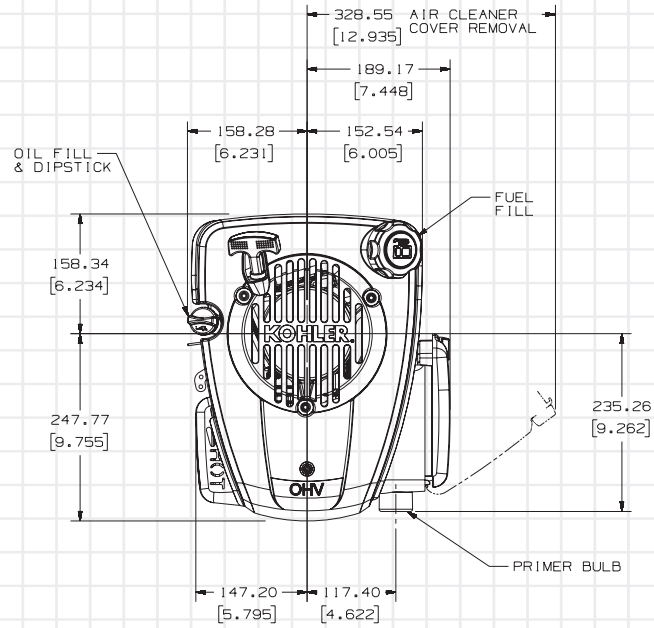

TOP VIEW

OIL FILL VIEW

PTO VIEW

XT-6

3.5 Net hp vertical-shaft engines

AIR FILTER VIEW

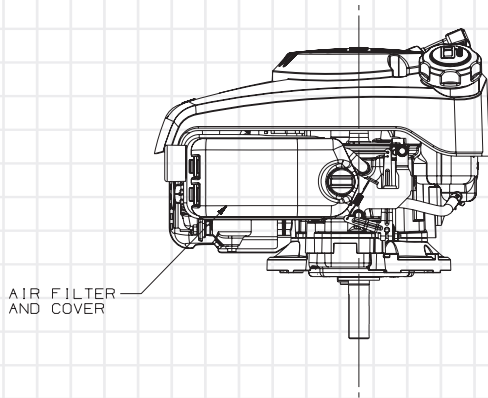

VALVE COVER VIEW

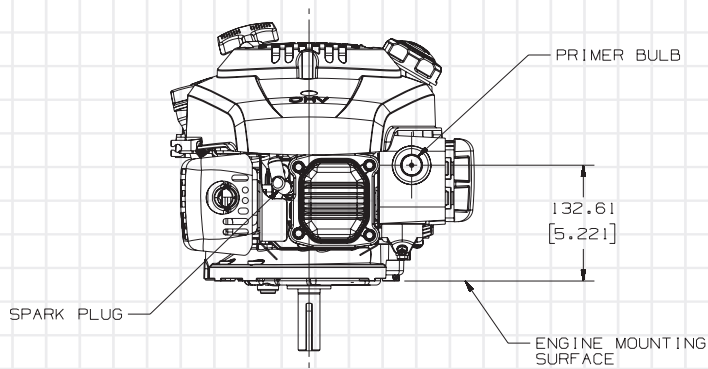

CRANKSHAFT EXTENSION

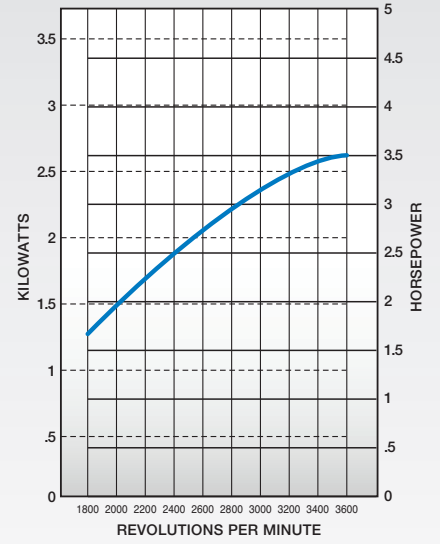
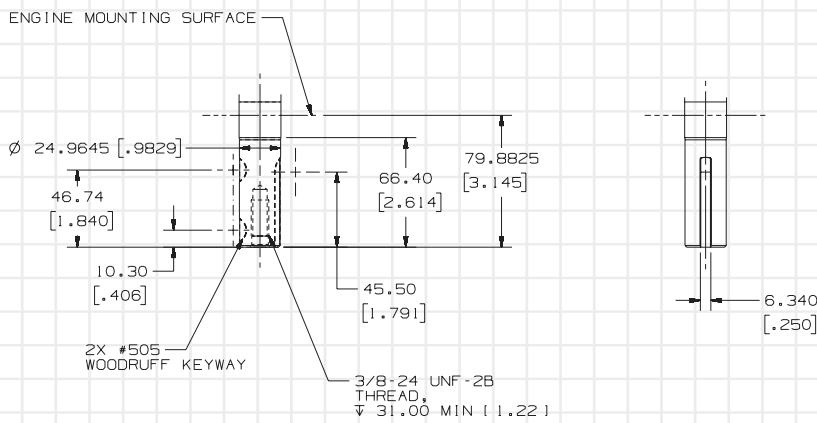

Maximum Power

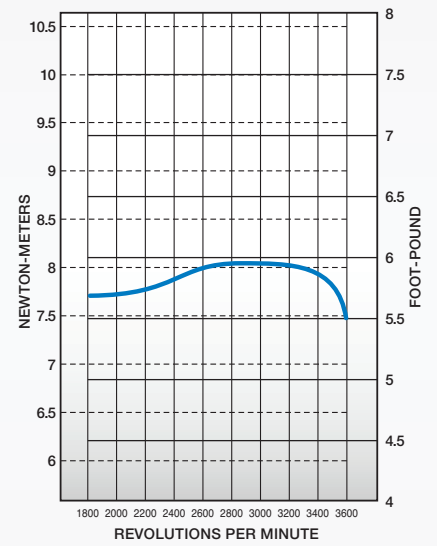

Maximum Torque

XT-6

XT-7 and XTR-7 4.5 Net hp vertical-shaft engines

KOHLER® COURAGE® ENGINE ARCHITECTURE

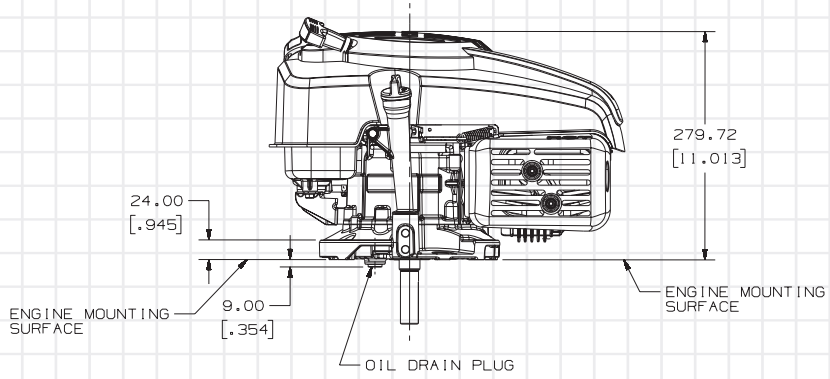

OIL FILL VIEW

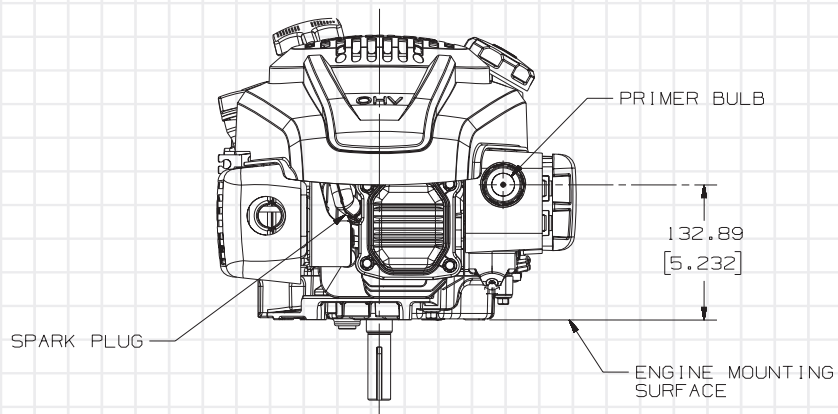

VALVE COVER VIEW

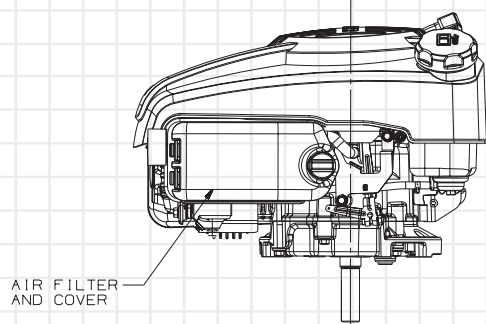

AIR FILTER VIEW

XT-7 and XTR-7 4.5 Net hp vertical-shaft engines

TOP VIEW

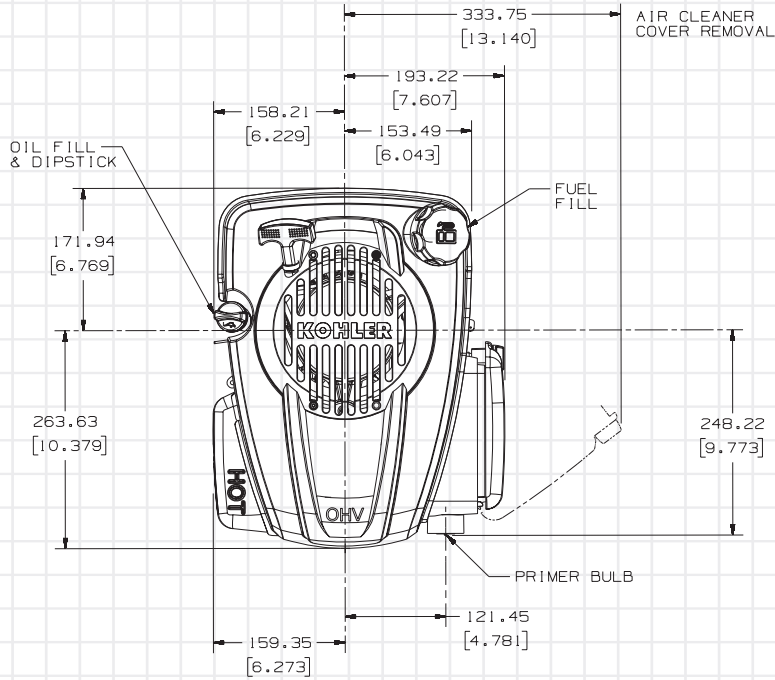

PTO VIEW

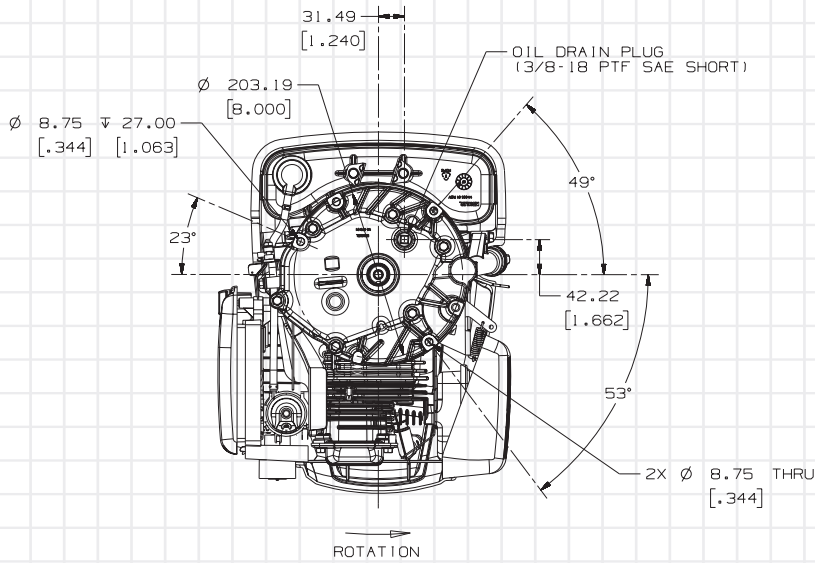

CRANKSHAFT EXTENSION

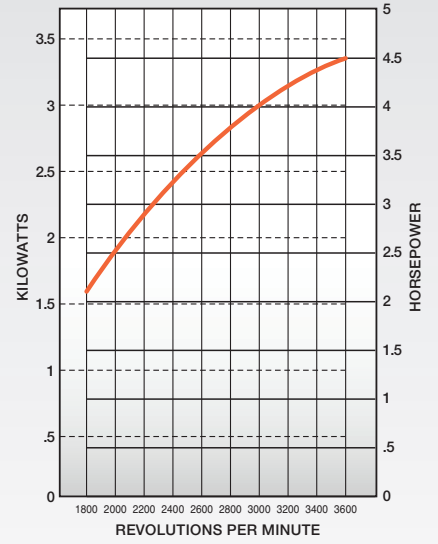
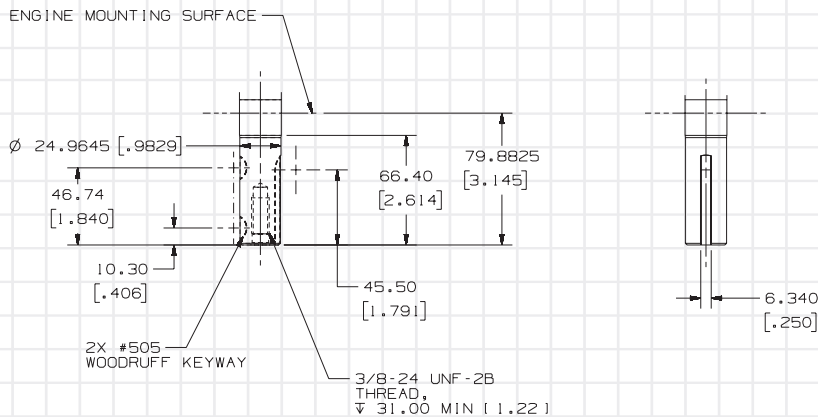

Maximum Power

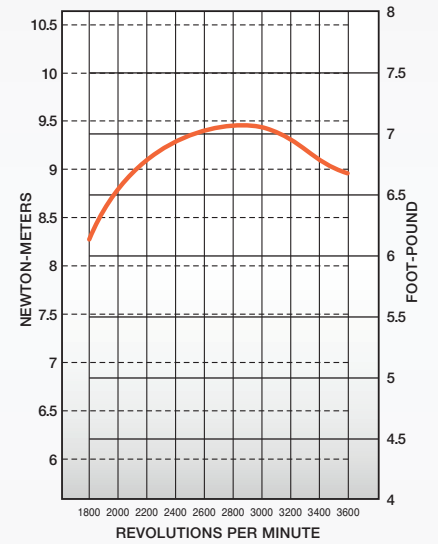

Maximum Torque

XT-7/XTR-7

KOHLER® Courage® XT-Series Model Specifications

Engine Type		Four-cycle, single-cylinder, air-cooled, vertical shaft, gasoline, OHV, with cast iron liner.		
Model		XT-6	XT-7	XTR-7
Net Peak Torque @ 2600 rpm	ft lb (Nm)	5.9 (8)	7 (9.5)	
Max Net Power @ 3600 rpm	hp (kW)	3.5 (2.6)	4.5 (3.5)	
Displacement	cu in (cc)	9.1 (149)	10.6 (173)	
Bore	in (mm)	2.6 (65)	2.7 (70)	
Stroke	in (mm)	1.8 (45)	1.8 (45)	
Compression Ratio		8.3:1	8.5:1	
Dry Weight	lb (kg)	24 (10.8)	29 (13.1)	
Lubrication		Splash		
Enrichment		Primer or Smart-Choke™		
Starting	U.S. qt (L)	Recoil		Electric
Fuel Capacity	U.S. qt (L)	1 (1.1)	1.5 (1.4)	
Oil Capacity	U.S. qt (L)	20 (.6)		
*Dimensions L x W x H	in (mm)	16 x 13.2 x 10.8 (406 x 336 x 274)	17.1 x 13.9 x 11 (434 x 353 x 278)	

Preliminary information, subject to change.

Horsepower ratings exceed Society of Automotive Engineers Small Engine Test Code J1940. Actual engine horsepower is lower and affected by, but not limited to, accessories (air cleaner, exhaust, charging, cooling, fuel pump, etc.), application, engine speed and ambient operating conditions (temperature, humidity and altitude). For more information, contact Kohler Co. Engine Engineering.

Kohler reserves the right to change product specifications, designs and equipment without notice and without incurring obligation.

* Length is front of blower housing to end of blower housing. Width is air cleaner to muffler guard. Height is mounting surface to grass screen.

Standard Features

- OHV
- Primer bulb
- Large fuel inlet
- Ergonomic pull handle
- Internally vented carburetor
- Yearly service intervals
- Flywheel ball bearing
- Fixed speed
- Flywheel brake
- Aluminum alloy with cast iron liner
- Extended yellow dipstick
- Pleated automotive style air filter
- Forged crankshaft
- Recoil start
- Muffler with international compliant guard
- International symbols
- Electronic ignition

Popular Factory Options

- Manual choke
- Blade brake clutch (BBC)
- CARB Tier III compliance
- Cast iron flywheel
- Variable speed
- Remote ignition shut-down
- Tethered fuel cap
- Kill switch
- Precleaner
- Fuel filter
- Smart-Choke
- Electric start

For more information, contact your KOHLER source of supply
Or call toll-free in the U.S. and Canada 1-800-544-2444.

Kohler Co., Kohler, Wisconsin 53044 Tel 920-457-4441 Fax 920-459-1570

KohlerEngines.com

© 2008 by Kohler Co. All rights reserved

KOHLER®

Relentless Power.
Legendary Performance.

Printed in U.S.A. E-2131-A 10/08