

- 3 cylinders
- 1870 cm³
- 30,9 kW/42,0 HP
- 3000 r.p.m.
- Nm 114,6@2000

Available homologation

- EPA TIER III □
- ECE R 24 ▲
- 2004/26/CE/GSE ○

Construction

- 4-stroke air cooled diesel engine
- Direct injection
- Axle blower air cooling
- Mechanical fuel lift pump
- Forced lubrication with gear pump
- Full flow oil filtration with external cartridge filter
- Automatic extra fuel starting device
- Torque regulator
- Centrifugal speed governor
- Crankcase in die-cast aluminium
- Electric starting
- Counter-clockwise rotation (viewed from power take-off side)
- Aluminium alloy independent heads
- Re-borable independent cast-iron cylinders
- Power take-off on flywheel
- Oil cooler



Applications

- Generating Set
- Welding Set
- High pressure cleaner
- Transporter
- Hydraulic power pack
- Agricultural pump

Specifications

Cylinders	N.	3
Displacement	cm ³	1870
Bore	mm	95
Stroke	mm	88
Compression ratio		17:1
Rating kW/HP	N (80/1269/CEE) ISO 1585	30,9/42,0
	NB ISO 3046 IFN	28,6/39,0
	NA ISO 3046 ICXN	26,3/35,8
Max. torque	Nm	114,5@2000
Max. torque 3 P.T.O.	Nm	38,8
Counterclockwise rotation		
Engine speed - 3 P.T.O. ratio		1:1,067
Max. torque - 4 P.T.O. ratio	Nm	23,8
Counterclockwise rotation		
Engine speed - 4 P.T.O. ratio		1:1,1
Minimum idling speed r.p.m.		800-900
Fuel tank capacity	l	15
Oil consumption	kg/h.	0,017
Oil sump capacity	l	5
Min. allowable oil pressure	bar	1,5-2,0
Max. allowable inclination for:		
- short periods of operation (max. time 30 minutes)		25°
- peak values (max. time 1 minute)		35°
Cap. of air required for correct combustion @ 3000 r.p.m.	l/min.	2400
Cap. of air required for correct cooling @ 3000 r.p.m.	l/min.	38000
Dry weight	kg	170
Recommended battery		
- till -10°C	V/Ah	12/66
- till -15°C	V/Ah	12/88

Minimum pulley diameters for belt drive

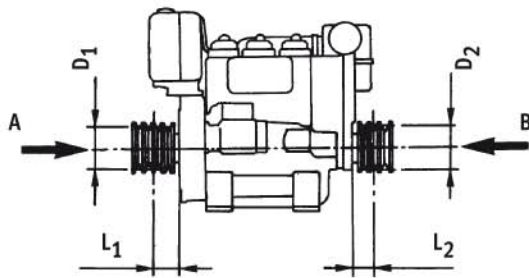

$$D_1 \text{ (mm)} \geq 100 [185 + L_1 \text{ (mm)}] \frac{N \text{ (kW)}}{n \text{ (RPM)}}$$

$$D_2 \text{ (mm)} \geq 113 [169 + L_2 \text{ (mm)}] \frac{N \text{ (kW)}}{n \text{ (RPM)}}$$

Max. intermittent axial load in both directions A-B = 600 kg



Sound pressure level dB (A)

Sound level polar diagram open field - 7 meters microphone - no load running engine.

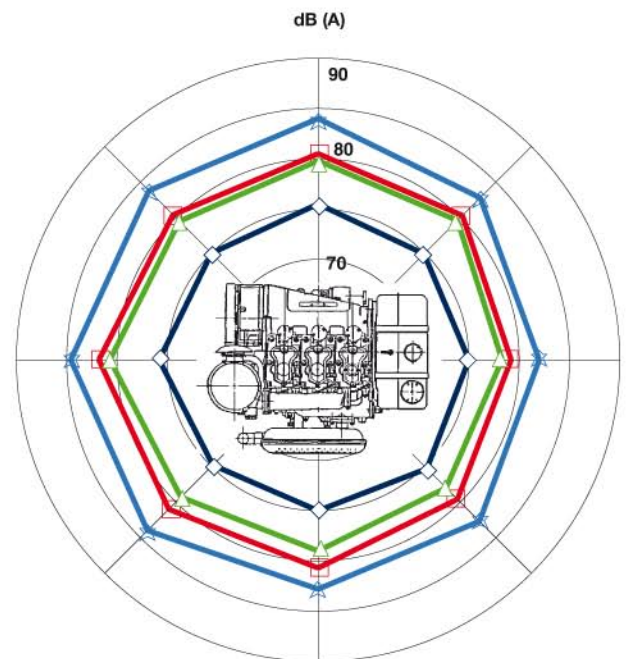

1500 RPM 2000 RPM 2500 RPM 3000 RPM

SERIE 11LD

Curves

11LD 626/3 NR @ 3000 r.p.m. ▲ ○

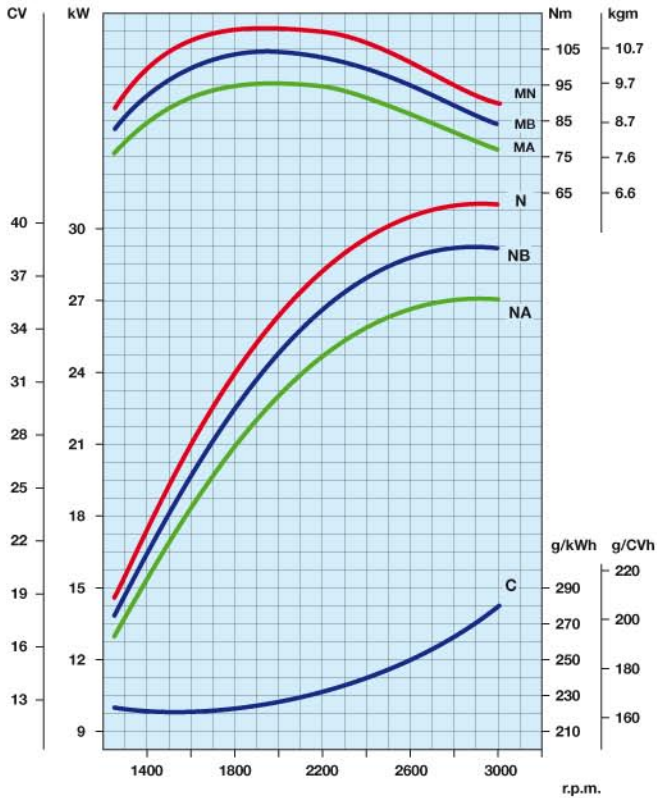

11LD 626/3 B2 NR @ 3000 r.p.m.

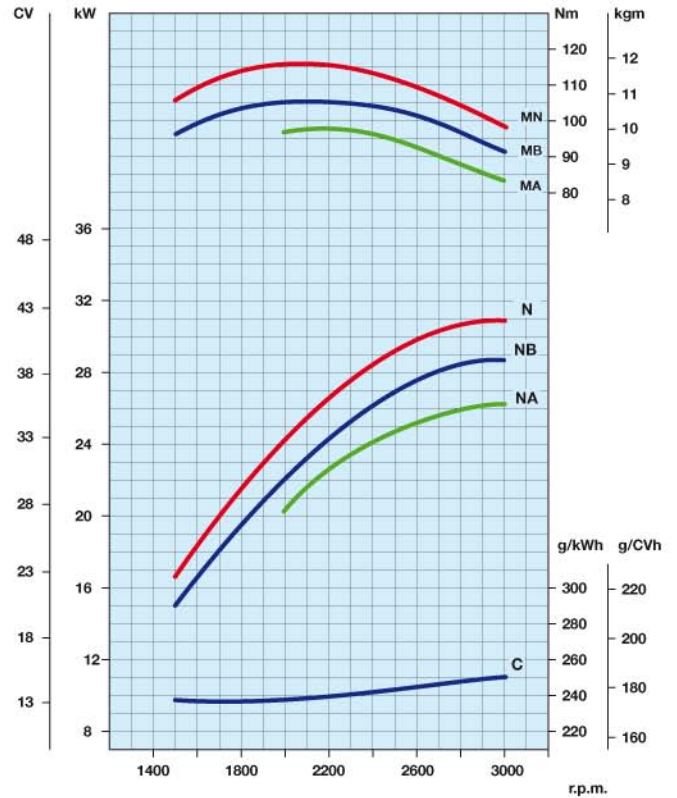

N Power curve - 80/1269/CEE - ISO 1585 -

NB Power curve - ISO 3046 - IFN -

NA Power curve - ISO 3046 - ICXN -

MN Torque curve - (N curve)

MB (NB curve) - **MA** (NA curve)

C Specific fuel consumption - (NB curve)

Power ratings refer to engines equiped with air filter, standard muffler, after being run in and in ambient conditions of 20°C and 1 bar. Power levels drop by 1% every 100m altitude and by 2% every 5°C above 20°C.

Output power for fixed speed application (including generating sets)

Engine power kW

r.p.m.	Intermittent (NB)	Continuous (NA)
3000	28,6	26,3
1800	20,0	18,0
1500	16,7	14,7

Technical drawings *

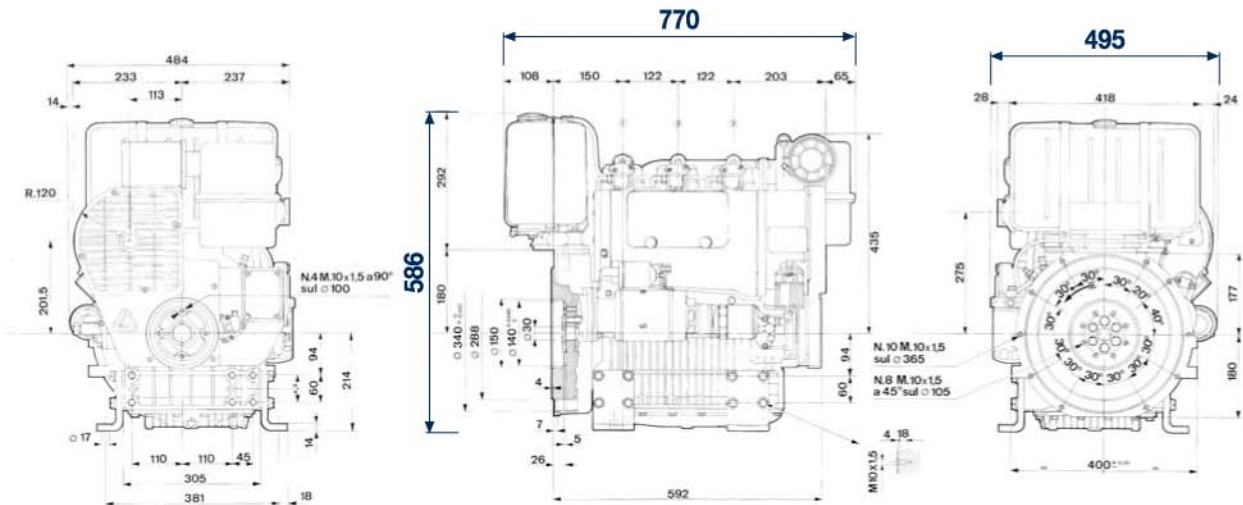

* More specific dimensions are available on www.lombardini.it (see table at the bottom of the page)

Standard equipment

- Electric starting with 12V starter motor and alternator
- Black paint on sheet metal parts
- Manual control accelerator (fixed)
- Oil bath air filter
- External fuel filter
- External oil filter
- Oil pressure switch
- Exhaust manifold and muffler
- Engine feet
- Power take-off on flywheel
- Keyswitch panel
- Fuel lift pump
- Counter-clockwise rotation on power take-off side
- Fuel tank
- Automatic extra fuel device
- Oil cooler
- Sound-proofing
- Guard for belt
- Use, maintenance and spare parts booklet

Accessories

- Different guards according to use
- Range of alternative alternators
- Flanges
- Detached dry air filter
- Cyclonic air prefilter
- Clutches
- Range of flywheels for various clutches
- Hydraulic pump adapters
- Range of fuel tanks of various sizes
- Mufflers and exhaust pipes
- Controls
- Pulleys
- Varnishing



ISO 9001 Cert. n. 0446 - 1405
QS. 9000 Cert. n. 2231/0



LOMBARDINI S.r.l. a Socio unico
Cap. Soc. € 44.000.000,00 int. ver. R.E.A. 227083
Reg. Imp. RE/CEE Code/P.IVA (IT) 01829970357
Via Cav. del Lavoro Adelmo Lombardini, 2
42124 Reggio Emilia - Italia
Tel. +39.0522.3891 - Fax +39.0522.389503
info@lombardini.it www.lombardini.it

Files for this product available on www.lombardini.it

Data sheet	16LD626DS.PDF
Owner manual	16LD626OM.PDF
Service manual	16LD626SM.PDF
Technical drawing	16LD626TD.DWG
Power curve	16LD626PC.PDF

LOMBARDINI RESERVES THE RIGHT TO MAKE MODIFICATIONS WITHOUT PRIOR NOTICE

cod. 35581400 - 11-2009