

- 1 cylinder
- 349 cm³
- 5,5 kW/7,5 HP
- 3600 r.p.m.
- Nm 16,6@2400

Available homologation

- EPA TIER II ●
- ECE R 24 ▲

Construction

- 4 -stroke air cooled diesel engine.
- Conical power take-off on crankshaft.
- Anticlockwise rotation.
- Direct injection.
- Forced lubrication with oil pump.
- Centrifugal mass governor.
- Built-in full flow oil filter.
- Oil breathing blow-by with safety device.
- Automatic extra fuel starting device.
- Self bleeding fuel system.
- Torque regulator.
- Automatic compression release.
- Die-cast aluminium crankcase with integral cast iron cylinder liner.
- Aluminium alloy cylinder head.
- Built-in rigid feet.



Applications

- Two-wheel tractor
- Agricultural mower
- Agricultural pump
- High pressure cleaner
- Generating set
- Vibrating plate

Specifications

Cylinders	N.	1
Displacement	cm ³	349
Bore	mm	82
Stroke	mm	66
Compression ratio		20,3:1
Rating kW/HP	N (80/1269/CEE) ISO 1585	5,5/7,5
	NB ISO 3046 IFN	5,1/7,0
	NA ISO 3046 ICXN	4,7/6,4
Max. torque	Nm	16,6@2400
Min. idling speed		950÷1000
Fuel tank capacity	l	4,3
Oil consumption	kg/h.	0,0032
Oil sump capacity	l	1,2
Min. allowable oil pressure	bar	1÷1,5
Max. allowable inclination for:		
- short periods of operation (max. time 30 minutes)		25°
- peak values (max. time 1 minute)		35°
Cap. of air required for correct combustion @ 3600 r.p.m.	l/min.	540
Cap. of air required for correct cooling @ 3600 r.p.m.	l/min.	5000
Dry weight	kg	33
Recommended battery	V/Ah	12/44
Minimum pulley diameters for belt drive		

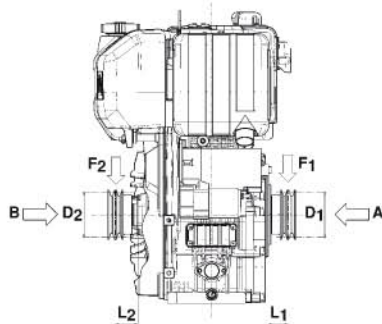
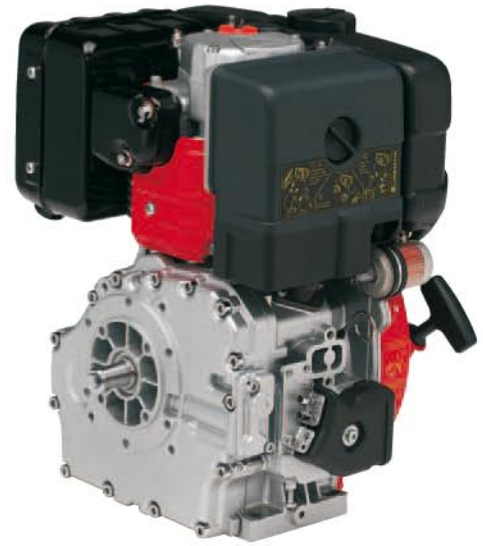

$$D_2 \text{ (mm)} \geq 860 [60 + L_2 \text{ (mm)}] \frac{N \text{ (kW)}}{n \text{ (RPM)}}$$

$$D_1 \text{ (mm)} \geq 820 [55 + L_1 \text{ (mm)}] \frac{N \text{ (kW)}}{n \text{ (RPM)}}$$

Max. intermittent axial load in both directions A-B = 200 kg

$$F_2 \text{ (N)} \leq \frac{67000}{60 + L_2 \text{ (mm)}}$$

$$F_1 \text{ (N)} \leq \frac{70000}{55 + L_1 \text{ (mm)}}$$

Maximum radial force on pulley for belt drive

Sound pressure level dB (A)

Sound level polar diagram open field - 7 meters microphone - no load running engine.

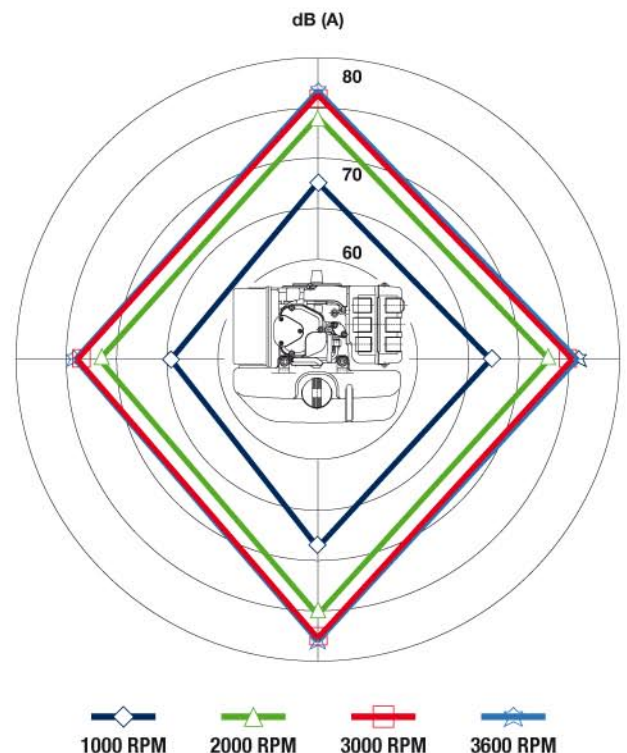

SERIE 15LD

Curves 15LD 350 ▲

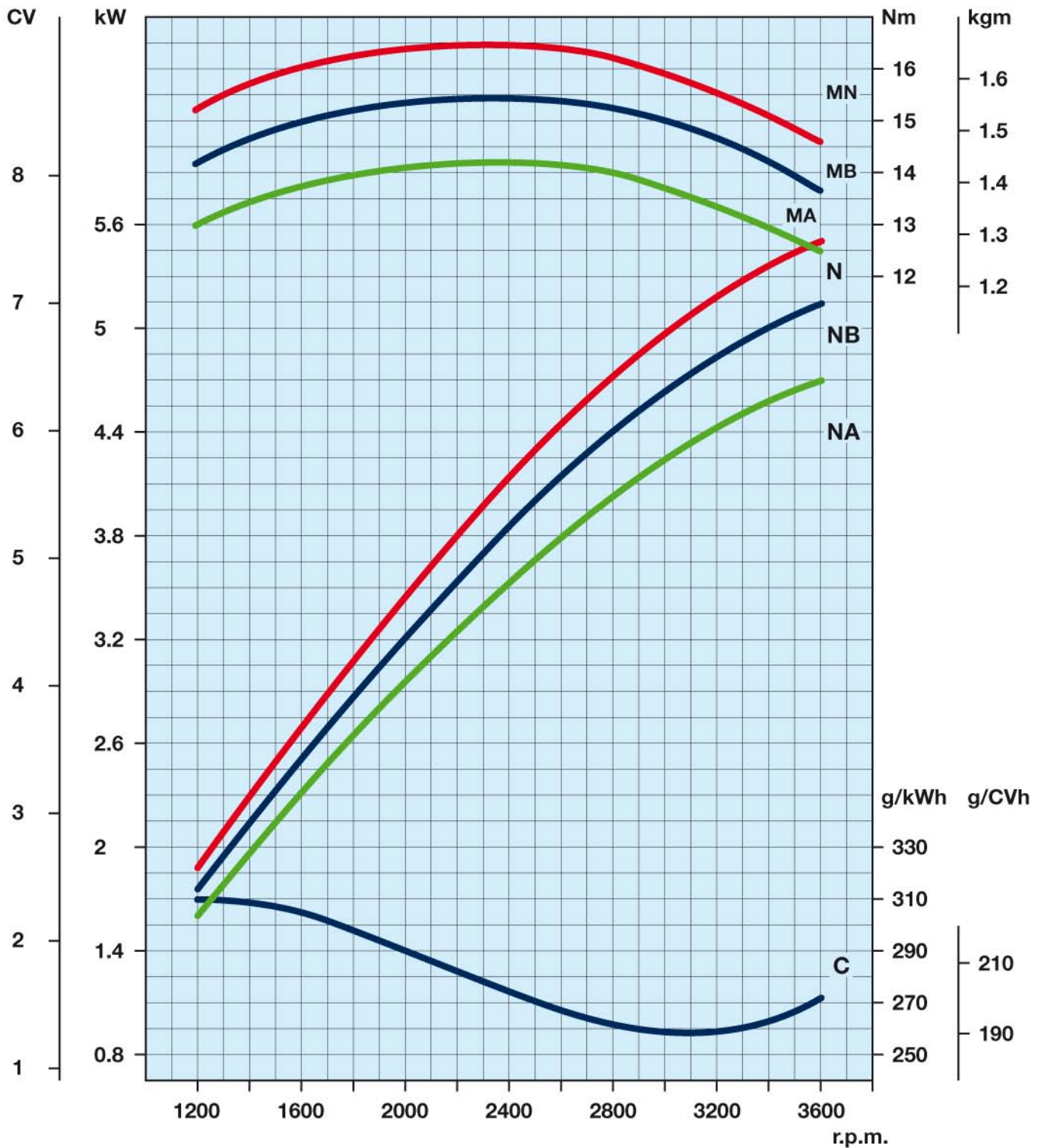

N Power curve - 80/1269/CEE - ISO 1585 -

NB Power curve - ISO 3046 - IFN -

NA Power curve - ISO 3046 - ICXN -

MN Torque curve - (N curve)

MB (NB curve) - MA (NA curve)

C Specific fuel consumption - (NB curve)

Power ratings refer to engines equiped with air filter, standard muffler, after being run in and in ambient conditions of 20°C and 1 bar. Power levels drop by 1% every 100m altitude and by 2% every 5°C above 20°C.

Technical drawings *

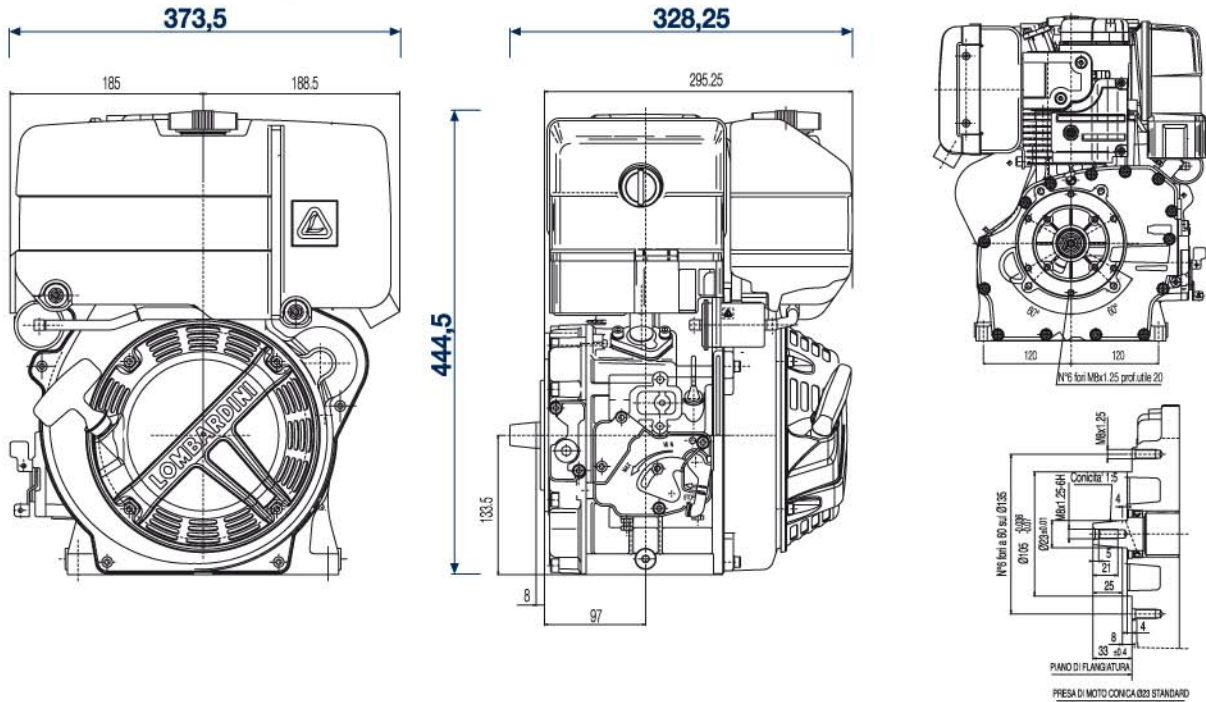

* More specific dimensions are available on www.lombardini.it (see table at the bottom of the page)

Standard equipment

- Recoil starting and automatic compression release
- Fuel tank
- Fuel filter
- Dry-air cleaner
- Muffler with guard
- Accelerator and stop manual control
- User maintenance-spare parts booklet

Accessories

- Power take-off flywheel side (engines with electrical starting)
- Power take-offs with flanging and special shaft
- Parallel crankshaft
- Internal dynamic balancer
- Oil-bath air-cleaner
- Electric start 12 V / 24 V
- Keyswitch panel
- Emergency stop through electrovalve
- Accelerator and stop remote control
- Key start panel with shutdown device
- Fuel lift pump
- Oil dipstick on cylinder head
- Oil pressure switch
- Oil temperature switch
- Glow plug on intake manifold
- Recoil with denoising cover
- Grass protection for engine cooling



ISO 9001 Cert. n. 0446 - 1405
QS. 9000 Cert. n. 2231/0



LOMBARDINI S.r.l. a Socio unico
Cap. Soc. € 44.000.000,00 int. ver. R.E.A. 227083
Reg. Imp. RE/CEE Code/P.IVA (IT) 01829970357
Via Cav. del Lavoro Adelmo Lombardini, 2
42124 Reggio Emilia - Italia
Tel. +39.0522.3891 - Fax +39.0522.389503
info@lombardini.it www.lombardini.it

Files for this product available on www.lombardini.it

Data sheet	15LD350DS.PDF
Owner manual	15LD350OM.PDF
Service manual	15LD350SM.PDF
Technical drawing	15LD350TD.DWG
Power curve	15LD350PC.PDF

LOMBARDINI RESERVES THE RIGHT TO MAKE MODIFICATIONS WITHOUT PRIOR NOTICE

cod. 35580890 - 11-2009