

- 2 cylinders
- 851 cm³
- 14,0 kW/19,0 HP
- 3600 r.p.m.
- Nm 42,0@2200

Available homologation

- EPA TIER II ●
- ECE R 24 ▲

Construction

- 4-stroke air cooled diesel engine
- Direct injection
- Flywheel fan air cooling
- Mechanical fuel feeding supplement
- Forced lubrication with oil pump
- Full flow oil filter with external cartridge
- Automatic mechanical fuel supplement
- Torque regulator
- Centrifugal speed governor
- Crankcase in die-cast aluminium
- Electric starting
- Counter-clockwise rotation (viewed from power take-off side)
- Aluminium alloy independent heads
- Independent cast-iron cylinders



Applications

- Dumper
- Vibrating Roller
- Generating Set
- Welding Set
- High pressure cleaner
- Hydraulic power pack
- Agricultural pump
- Two-wheel tractor

Specifications

Cylinders	N.	2	
Displacement	cm ³	851	
Bore	mm	85	
Stroke	mm	75	
Compression ratio		19:1	
Rating kW/HP	N (80/1269/CEE) ISO 1585	14,0/19,0	
	NB ISO 3046 IFN	13,0/17,7	
	NA ISO 3046 ICXN	12,0/16,3	
Max. torque	Nm	42,0@2200	
Max. torque 3 P.T.O.	Nm	18,0	
Counterclockwise rotation			
Engine speed - 3 P.T.O. ratio		1:0,87	
Minimum idling speed r.p.m.		1000	
Fuel tank capacity	l	4	
Oil consumption	kg/h.	0,0085	
Oil sump capacity	l	1,8	
Min. allowable oil pressure	bar	0,8	
Max. allowable inclination for:			
- short periods of operation (max. time 30 minutes)		25°	
- peak values (max. time 1 minute)		35°	
Cap. of air required for correct combustion @ 3600/3000 r.p.m.	l/min.	1330/1110	
Cap. of air required for correct cooling @ 3600/3000 r.p.m.	l/min.	14200/11835	
Dry weight	kg	63	
Recommended battery	V/Ah	12/55	
Axial load	(continuous)	kg	100
	(intermittent)	kg	300

Minimum pulley diameters for belt drive

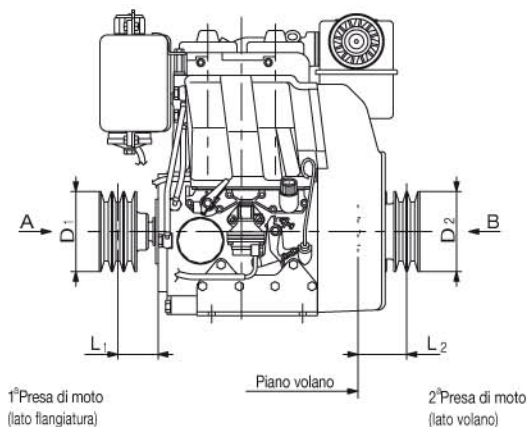

$$D_1 \text{ (mm)} \geq 700 [45+L_1 \text{ (mm)}] \quad \frac{N \text{ (kW)}}{n \text{ (RPM)}}$$

$$D_2 \text{ (mm)} \geq 1540 [17+L_2 \text{ (mm)}] \quad \frac{N \text{ (kW)}}{n \text{ (RPM)}}$$

Max. intermittent axial load in both directions A-B = 300 kg

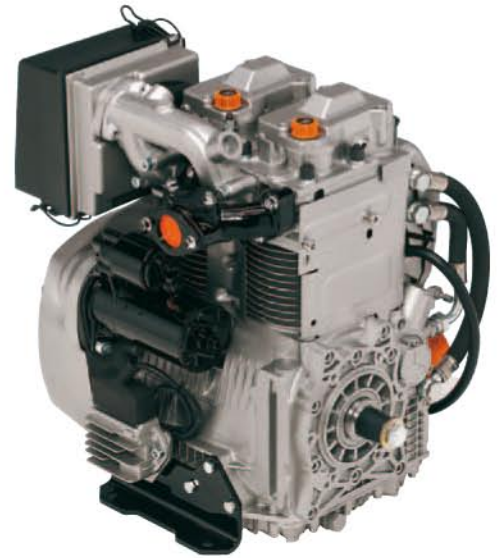

Sound pressure level dB (A)

Sound level polar diagram open field - 7 meters microphone - no load running engine.

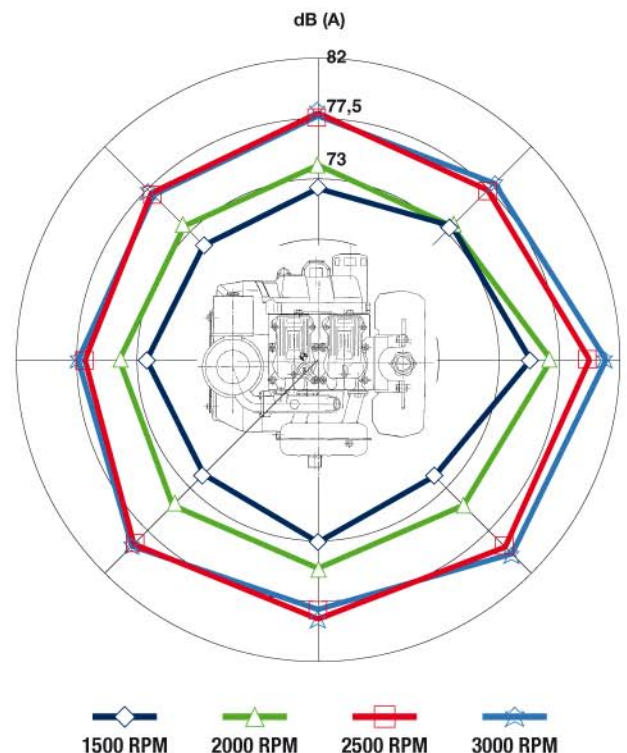

SERIE 25LD

Curves

25LD 425/2 B2 @ 3600 r.p.m. ▲

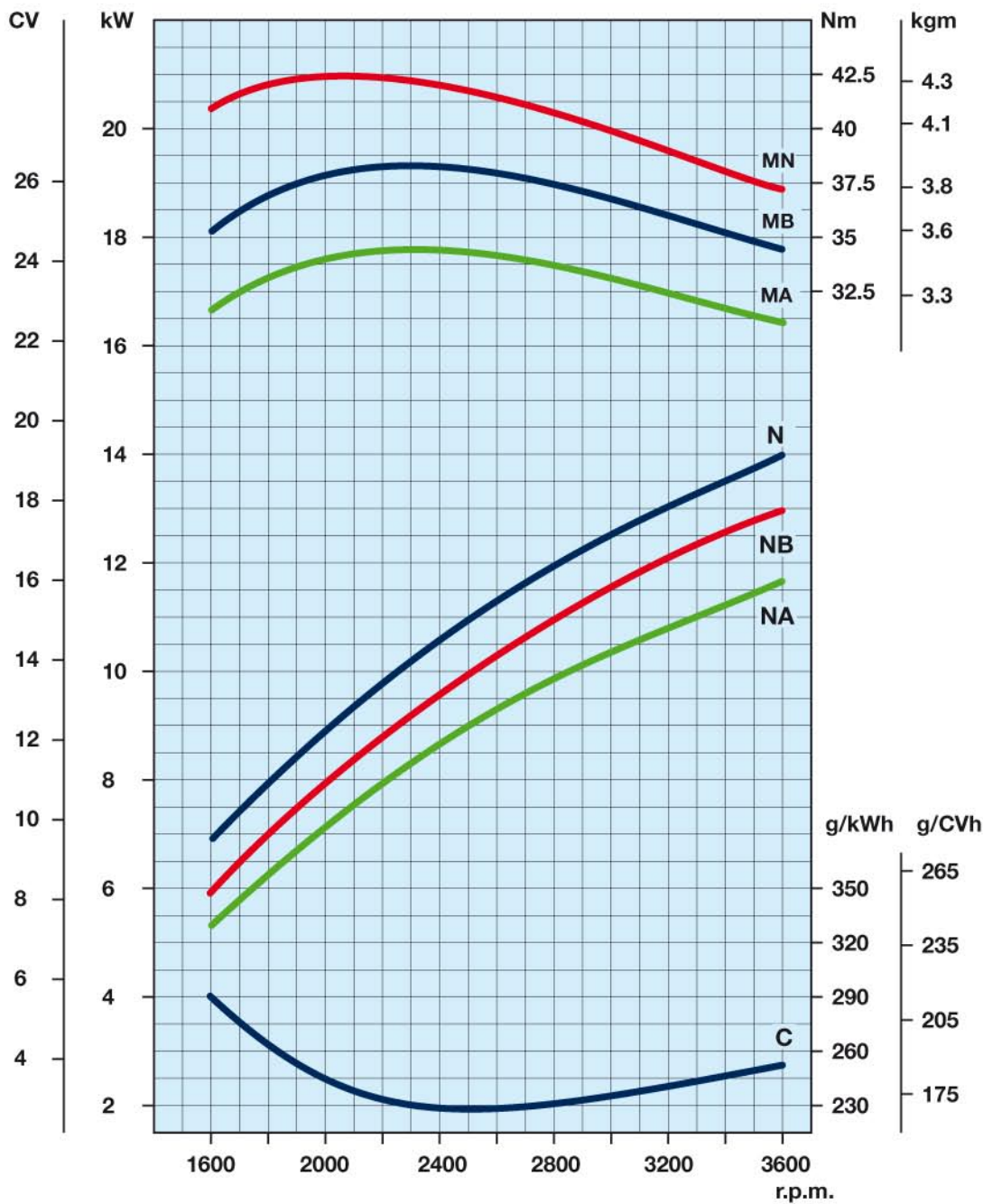

- N** Power curve - 80/1269/CEE - ISO 1585 -

- NB** Power curve - ISO 3046 - IFN -

- NA** Power curve - ISO 3046 - ICXN -

- MN** Torque curve - (N curve)

- MB** (NB curve) - **MA** (NA curve)

- C** Specific fuel consumption - (NB curve)

Output power for fixed speed application (including generating sets)

Engine power kW

r.p.m.	Intermittent (NB)	Continuous (NA)
3600	13,0	12,0
3000	11,5	10,5

Power ratings refer to engines equippe with air filter, standard muffler, after being run in and in ambient conditions of 20°C and 1 bar. Power levels drop by 1% every 100m altitude and by 2% every 5°C above 20°C.

Technical drawings *

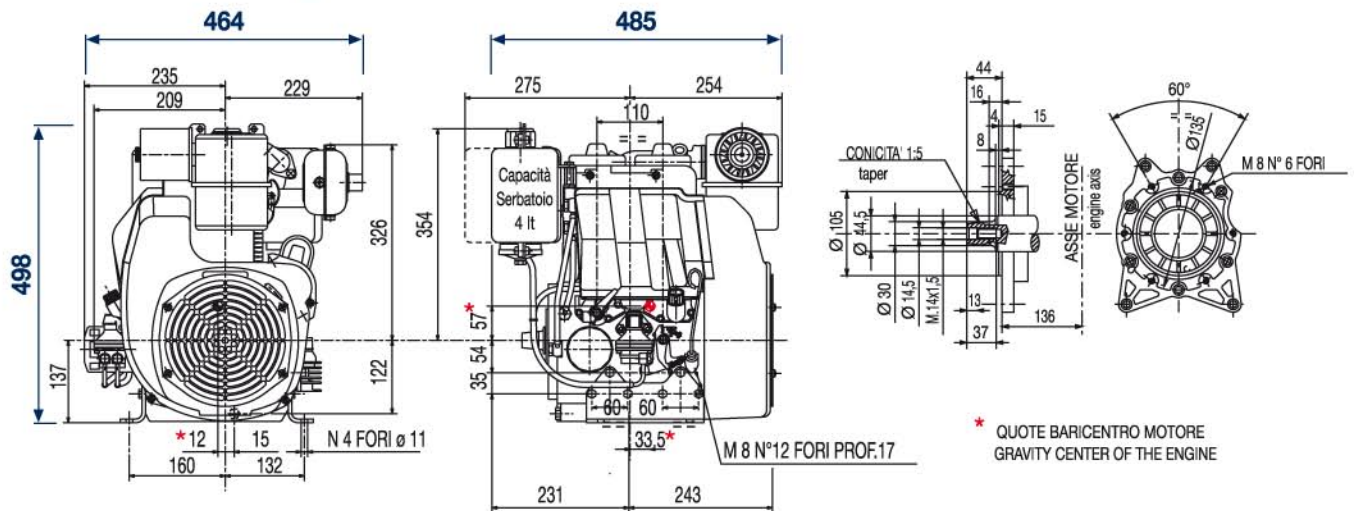

* More specific dimensions are available on www.lombardini.it (see table at the bottom of the page)

Standard equipment

- Electric starter with 12V alternator
- Black paint on sheet metal parts
- Remote throttle
- Oil bath air filter with prefilter
- External oil filter
- Oil pressure switch
- Combined manifold and exhaust muffler
- Engine feet
- Power take-off on crankshaft
- Keyswitch panel
- Fuel lift pump
- Counter-clockwise rotation on power take-off side
- Fuel tank with filter
- Automatic extra fuel device
- Oil cooler
- Use, maintenance and spare parts booklet

Accessories

- Different guards according to use
- Range of alternative alternators
- Compression release
- Flanges
- Dry air filter
- External fuel filter
- Clutches
- Range of flywheels for various clutches
- Hydraulic pump adapters
- Range of fuel tanks of various sizes
- Mufflers and exhaust pipes
- Controls
- Pulleys
- Varnishing



ISO 9001 Cert. n. 0446 - 1405
QS. 9000 Cert. n. 2231/0



LOMBARDINI S.r.l. a Socio unico
Cap. Soc. € 44.000.000,00 int. ver. R.E.A. 227083
Reg. Imp. RE/CEE Code/P.IVA (IT) 01829970357
Via Cav. del Lavoro Adelmo Lombardini, 2
42124 Reggio Emilia - Italia
Tel. +39.0522.3891 - Fax +39.0522.389503
info@lombardini.it www.lombardini.it

Files for this product available on www.lombardini.it

Data sheet	25LD425DS.PDF
Owner manual	25LD425OM.PDF
Service manual	25LD425SM.PDF
Technical drawing	25LD425TD.DWG
Power curve	25LD425PC.PDF

LOMBARDINI RESERVES THE RIGHT TO MAKE MODIFICATIONS WITHOUT PRIOR NOTICE

cod. 35582040 - 11-2009