



- 2 cylinders
- 1248 cm³
- 21,0 kW/28,5 HP
- 3000 r.p.m.
- Nm 67,0@2000

Available homologation

- EPA TIER IV 
- 97/68/CE Step II 
- ECE R 24 

Construction

- 4-stroke air cooled diesel engine
- Direct injection
- Air cooled by fan integral to the flywheel
- Mechanical fuel lift pump
- Forced lubrication with gear pump
- Full flow oil filtration with external cartridge filter
- Automatic extra fuel starting device
- Torque regulator
- Centrifugal speed governor
- Crankcase in die-cast aluminium
- Electric starting
- Counter-clockwise rotation (viewed from power take-off side)
- Aluminium alloy independent heads
- Independent cast-iron cylinders
- Power take-off on crankcase



Applications

- Dumper
- Vibrating Roller
- Generating Set
- Welding Set
- High pressure cleaner
- Transporter
- Hydraulic power pack
- Agricultural pump
- Two-wheel tractor
- Tractor

Specifiche tecniche

Cylinders	N	2
Displacement	cm ³	1248
Bore	mm	95
Stroke	mm	88
Compression ratio		17,5:1
Rating kW/HP	N (80/1269/CEE) ISO 1585	21,0/28,5
	NB ISO 3046 IFN	18,8/25,5
	NA ISO 3046 ICXN	16,9/23,0
Max. torque	Nm	67,0@2000
Max. torque 3 P.T.O.	Nm	30,0
Engine speed - 3 P.T.O. ratio*		1:1
Minimum idling speed r.p.m.		1000÷1100
Fuel tank capacity	l	10
Oil consumption	kg/h	0,013
Oil sump capacity	l	2,8
Min. allowable oil pressure	bar	1
Max. allowable inclination for:		
- short periods of operation (max. time 30 minutes)		25°
- peak values (max. time 1 minute)		35°
Cap. of air required for correct combustion @ 3000 r.p.m.	l/min	1600
Cap. of air required for correct cooling @ 3000 r.p.m.	l/min	26300
Dry weight	kg	115
Recommended battery	V/Ah	12/66
Minimum pulley diameters for belt drive		

*Clockwise rotation from side of 2nd PTO

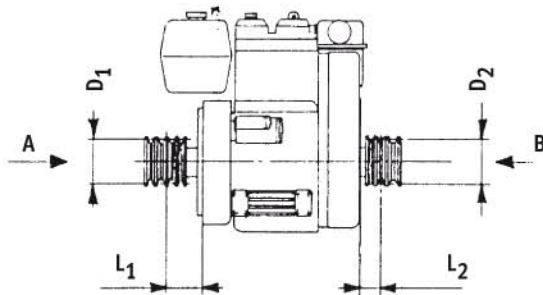

$$D_1 \text{ (mm)} \geq 136 [162 + L_1 \text{ (mm)}] \frac{N \text{ (kW)}}{n \text{ (RPM)}}$$

$$D_2 \text{ (mm)} \geq 204 [260 + L_2 \text{ (mm)}] \frac{N \text{ (kW)}}{n \text{ (RPM)}}$$

Max. intermittent axial load in both directions A-B = 300 kg

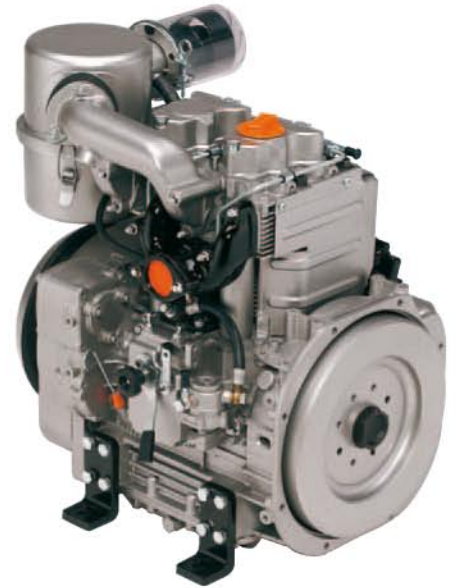

Sound pressure level dB (A)

Sound level polar diagram open field - 7 meters microphone - no load running engine.

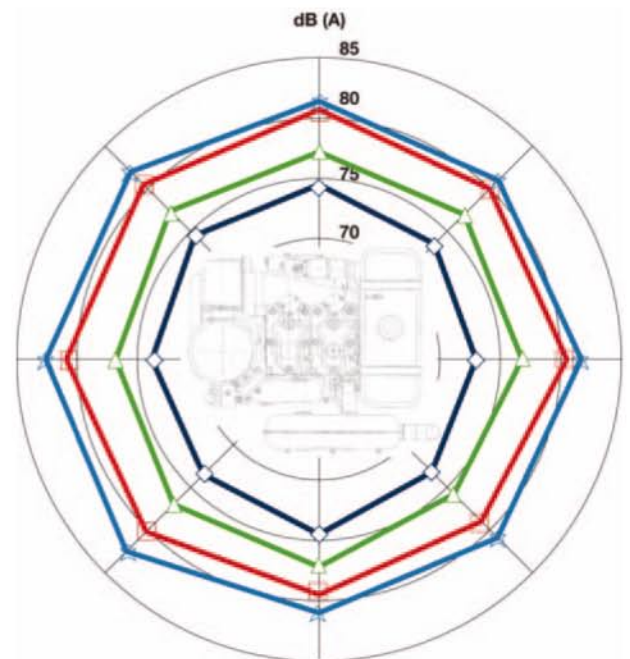

1500 RPM 2000 RPM 2500 RPM 3000 RPM

SERIE 9LD

Curves

9LD625 @ 3000 r.p.m. ◀ ▲

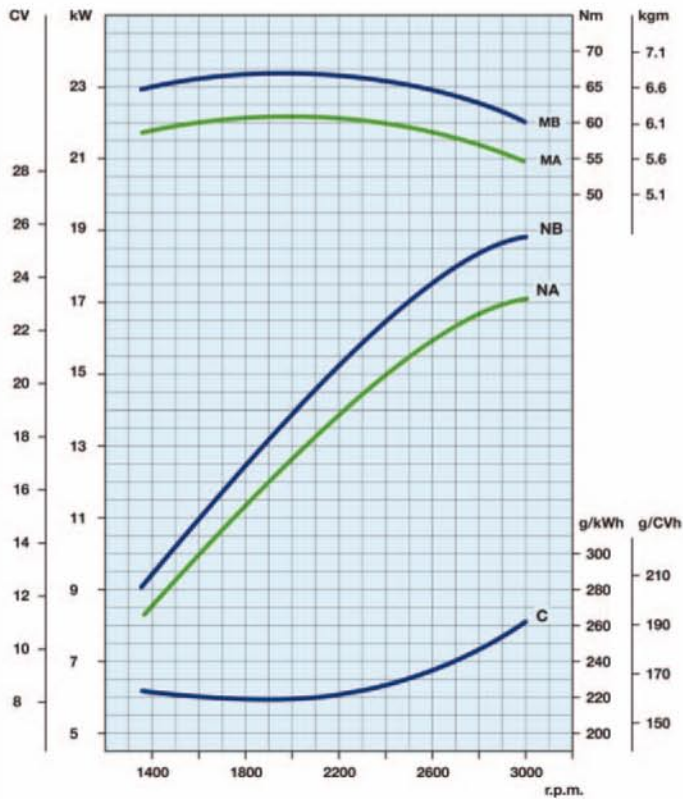

9LD626/2 B2 NR @ 2800 r.p.m. ◀ ▲

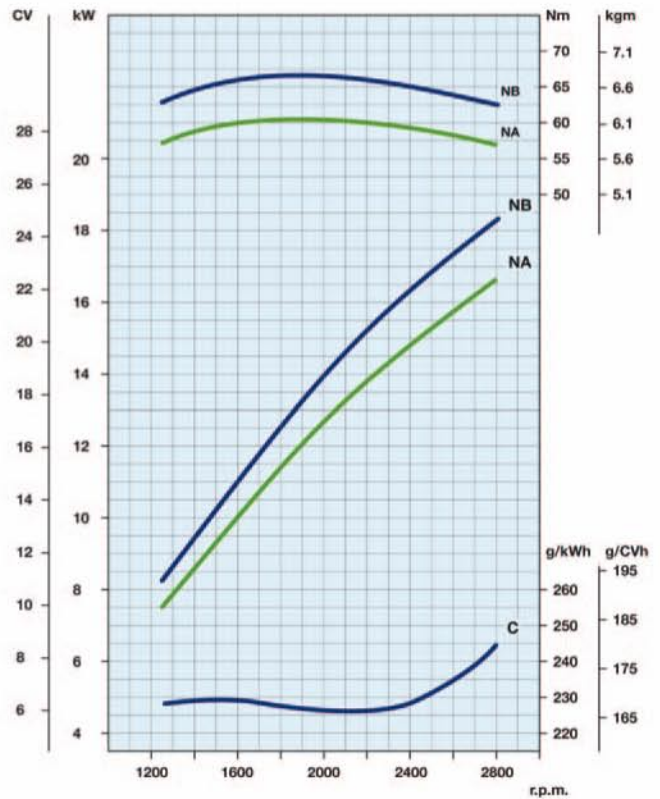

9LD625/2 @ 3000 r.p.m. ◀ ▲

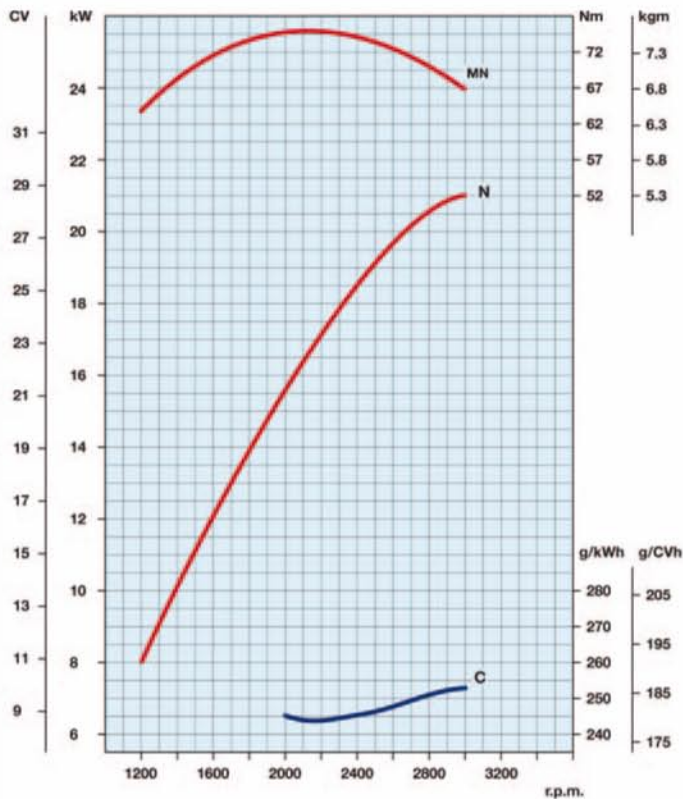

- N** Power curve - 80/1269/CEE - ISO 1585 -
- NB** Power curve - ISO 3046 - IFN -
- NA** Power curve - ISO 3046 - ICXN -
- MN** Torque curve - (N curve)
- MB (NB curve) - MA (NA curve)**
- C** Specific fuel consumption - (NB curve)

Power ratings refer to engines equipped with air filter, standard muffler, after being run in and in ambient conditions of 20°C and 1 bar. Power levels drop by 1% every 100m altitude and by 2% every 5°C above 20°C.

Output power for fixed speed application (including generating sets)

Engine power kW

r.p.m.	Intermittent (NB)	Continuous (NA)
3000	18,8	17,1
1800	13,5	12,0
1500	10,7	9,7

Technical drawings *

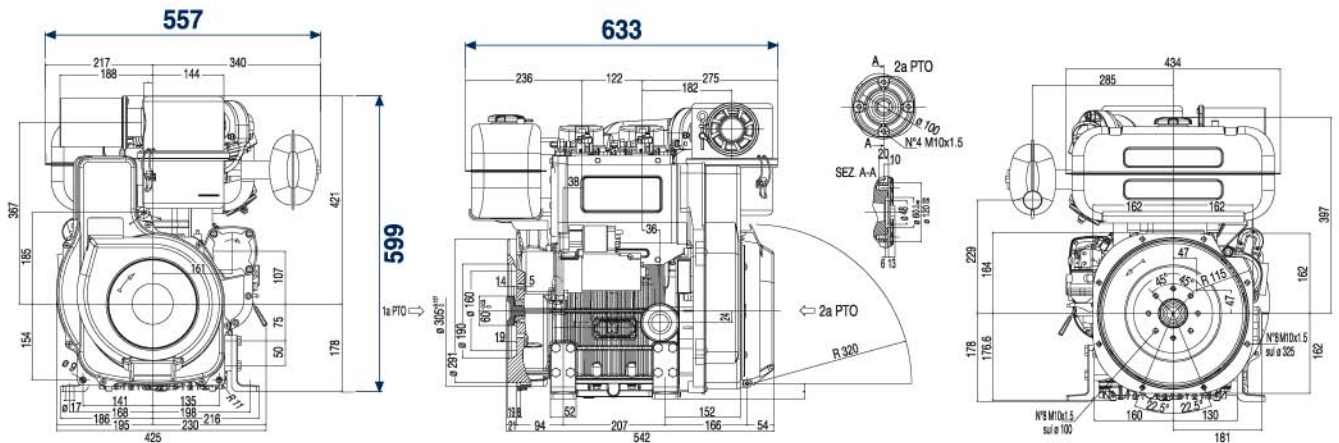

* More specific dimensions are available on www.lombardini.it (see table at the bottom of the page)

Standard equipment

- Electric starting with 12V starter motor and alternator
- Black paint on sheet metal parts
- Manual control accelerator (fixed)
- Oil bath air filter with cyclonic prefilter
- External oil filter
- Oil pressure switch
- Combined manifold and exhaust muffler
- Engine feet
- Power take-off on flywheel
- Keyswitch panel
- Fuel lift pump
- Counter-clockwise rotation on power take-off side
- Fuel tank with filter
- Automatic extra fuel device
- Sound-proofing
- Use, maintenance and spare parts booklet

Accessories

- Different guards according to use
- Range of alternative alternators
- Compression release
- Flanges
- Clutches
- Hydraulic pump adapters
- Gear adapters
- Range of fuel tanks of various sizes
- Mufflers and exhaust pipes
- Controls
- Pulleys
- Oil cooler
- Crank starter
- Varnishing



ISO 9001 Cert. n. 0446 - 1405
QS. 9000 Cert. n. 2231/0



LOMBARDINI S.r.l. a Socio unico
Cap. Soc. € 44.000.000,00 int. ver. R.E.A. 227083
Reg. Imp. RE/CEE Code/P.IVA (IT) 01829970357
Via Cav. del Lavoro Adelmo Lombardini, 2
42124 Reggio Emilia - Italia
Tel. +39.0522.3891 - Fax +39.0522.389503
info@lombardini.it www.lombardini.it

Files for this product available on www.lombardini.it

Data sheet	9LD625DS.PDF
Owner manual	9LD625OM.PDF
Service manual	9LD625SM.PDF
Technical drawing	9LD625TD.DWG
Power curve	9LD625PC.PDF

LOMBARDINI RESERVES THE RIGHT TO MAKE MODIFICATIONS WITHOUT PRIOR NOTICE

cod. 35583050 - 11-2009