

V O L V O



Volvo Excavators 30.0 - 32.7 t 245 hp

EC300

Volvo Construction Equipment

EC300

**A versatile machine regardless of application.
A modern, comfortable cab helps operators perform
at their very best, giving you an edge in productivity.**



A straightforward solution

Commonly used in quarries, for trenching, digging or preparing construction sites, the EC300 is a versatile machine. Regardless of applications, the EC300F is a straightforward solution with big payback. With enhanced machine access, superior visibility, increased service intervals, improved fuel efficiency, this excavator delivers all the safety, comfort, reliability and performance you would expect from a Volvo machine.



Operator comfort

- More precise controls
- Quieter cab
- Personalized settings for greater comfort
- ROPS cab as standard



Serviceability

- Ground level access for service
- Long service intervals
- Grouped filters and lubrication points
- Quick and easy oil changes



Fuel Efficiency

- Up to 15% improvement
- Powerful and efficient Volvo engine
- Engine pump optimization
- Hydraulic system improvement with smart MCV



Productivity

- Volvo Active Control
- Dig Assist with On-Board Weighing
- Boom/Swing & Boom/Travel priority functions

Volvo EC300 in Detail

Engine

Engine	Volvo	D8L
Max power at	r/min	1 720
Net, ISO 9249/SAE J1349	kW	179
	hp	243
Gross, ISO 14396/SAE J1995	kW	180
	hp	245
Max torque	Nm	1 250
at engine speed	r/min	1 300
No. of cylinders		6
Displacement	l	7.7
Bore	mm	110
Stroke	mm	135

Electrical system

Voltage	V	24
Batteries	V	2 x 12
Battery capacity	Ah	180 x 2
Alternator	V/A	28 / 120
Start motor	V - kW	24 - 5.5

Undercarriage and structures

The undercarriage has a robust X-shaped frame. Greased and sealed track chains are standard.			
Track shoe			2 x 50
Link pitch	mm		203
Shoe width, triple grouser	mm		600 / 700 / 800 / 900
Shoe width, single grouser	mm		700
Bottom rollers			2 x 9
Top rollers			2 x 2

Swing system

The swing system uses an axial piston motors, driving a planetary gearbox for maximum torque. An automatic holding brake and antirebound valve are standard.

Max. slew speed	r/min	10.8
Max. slew torque	kNm	114.8

Travel System

Each track is powered by an automatic two-speed shift travel motor. The track brakes are multi-disc, spring-applied and hydraulic released. The travel motor, brake and planetary gears are well protected within the track frame.

Max. drawbar pull	kN	248
Max. travel speed (low)	km/h	3.6
Max. travel speed (high)	km/h	5.4
Gradeability	°	35

Cab

The operator's cab has easy access via a wide door opening. The cab is supported on hydraulic dampening mounts to reduce shock and vibration levels. These along with sound absorbing lining provide low noise levels. The cab has excellent all-round visibility. The front windshield can easily slide up into the ceiling, and the lower front glass can be removed and stored in the side door.

Integrated airconditioning and heating system: The pressurized and filtered cab air is supplied by an automatically controlled fan. The air is distributed throughout the cab from 14 vents.

Ergonomic operator's seat: The adjustable seat and joystick console move independently to accommodate the operator. The seat has 12 different adjustments plus a seat belt for the operator's comfort and safety. Refrigerant of the type R134a is used when this machine is equipped with air conditioning. Contains fluorinated greenhouse gas R134a, Global Warming Potential 1430 CO₂-eq.

Sound Level

Sound pressure level in cab according to ISO 6396

L _{pA}	dB	76
-----------------	----	----

External sound level according to ISO 6395 and EU Noise Directive 2000/14/EC

L _{WA}	dB	106
-----------------	----	-----

Service Refill

Fuel tank	l	450
Hydraulic system, total	l	400
Hydraulic tank	l	210
Engine oil	l	30
Engine coolant	l	44
Slew reduction unit	l	6
Travel reduction unit	l	2 x 6

Hydraulic system

The new electro-hydraulic system and new MCV (main control valve) use intelligent technology to control on-demand flow for high productivity, high-digging capacity and excellent fuel consumption.

The following important functions are included in the system for optimum performance:

Summation system: Combines the flow of both hydraulic pumps to ensure quick cycle times and high productivity.

Boom priority: Gives priority to the boom operation for faster raising when loading or performing deep excavations.

Arm priority: Gives priority to the arm operation for faster cycle times in leveling and for increased bucket filling when digging.

Swing priority: Gives priority to swing functions for faster simultaneous operations.

Regeneration system: Prevents cavitation and provides flow to other movements during simultaneous operations for maximum productivity.

Power boost: All digging and lifting forces are increased.

Holding valves: Boom and arm holding valves prevent the digging equipment from creeping.

Main pump: 2 x variable displacement axial piston pumps

Maximum flow	l/min	2 x 276
--------------	-------	---------

Pilot pump: Gear pump

Maximum flow	l/min	20
--------------	-------	----

Max. pressure		33.3 / 36.3
----------------------	--	-------------

Implement	MPa	33.3 / 37.8
-----------	-----	-------------

Travel circuit	MPa	36.3
----------------	-----	------

Slew circuit	MPa	28.9
--------------	-----	------

Pilot circuit	MPa	3.9
---------------	-----	-----

Hydraulic Cylinders

Mono boom		2
-----------	--	---

Bore x Stroke	ø x mm	140 x 1 480
---------------	--------	-------------

Arm		1
-----	--	---

Bore x Stroke	ø x mm	150 x 1 745
---------------	--------	-------------

Bucket		1
--------	--	---

Bore x Stroke	ø x mm	140 x 1 140
---------------	--------	-------------

ME Bucket		1
-----------	--	---

Bucket for LR boom		1
--------------------	--	---

Bore x Stroke	ø x mm	100 x 865
---------------	--------	-----------

Specifications

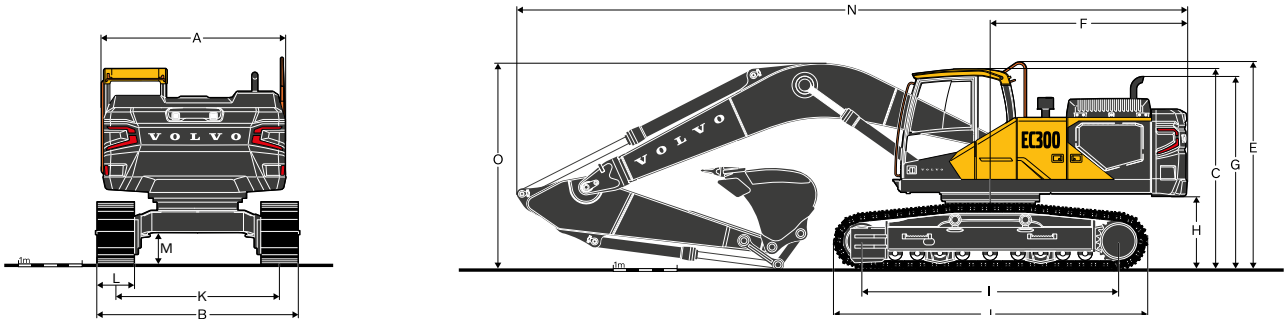

DIMENSIONS

	Unit	EC300F L		EC300F LR
Boom	m	6.2		10.2
Arm	m	2.55	3.05	7.9
A. Overall width of upper structure	mm	2 890	2 890	2 890
B. Overall width	mm	3 190	3 190	3 390
C. Overall height of cab	mm	3 110	3 110	3 110
D. Overall height of handrail	mm	3 200	3 200	3 200
F. Tail swing radius	mm	3 120	3 120	3 120
G. Overall height of engine hood	mm	2 740	2 740	2 740
H. Counterweight clearance *	mm	1 105	1 105	1 105
I. Tumbler length	mm	4 015	4 015	4 015
J. Track length	mm	4 865	4 865	4 865
K. Track gauge	mm	2 590	2 590	2 590
L. Shoe width	mm	600	600	600
M. Min. ground clearance *	mm	475	475	475
N. Overall length	mm	10 600	10 500	14 555
O. Overall height of boom	mm	3 460	3 335	3 320

* Without shoe grouser

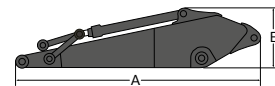
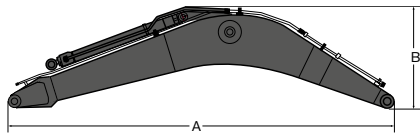

DIMENSIONS

Description	Unit	Boom		Description	Unit	Arm		
	m	6.2 HD	6.2 XD		m	2.55 HD	3.05 HD	3.05 XD
A. Length	mm	6 419	6 419	A. Length	mm	3 720	4 145	4 145
B. Height	mm	1 780	1 780	B. Height	mm	1 005	1 010	1 010
Width	mm	766	766	Width	mm	560	560	560
Weight	kg	2 755	2 885	Weight	kg	1 525	1 595	1 680

* Includes arm cylinder, piping and pin

* Includes cylinder, linkage and pin

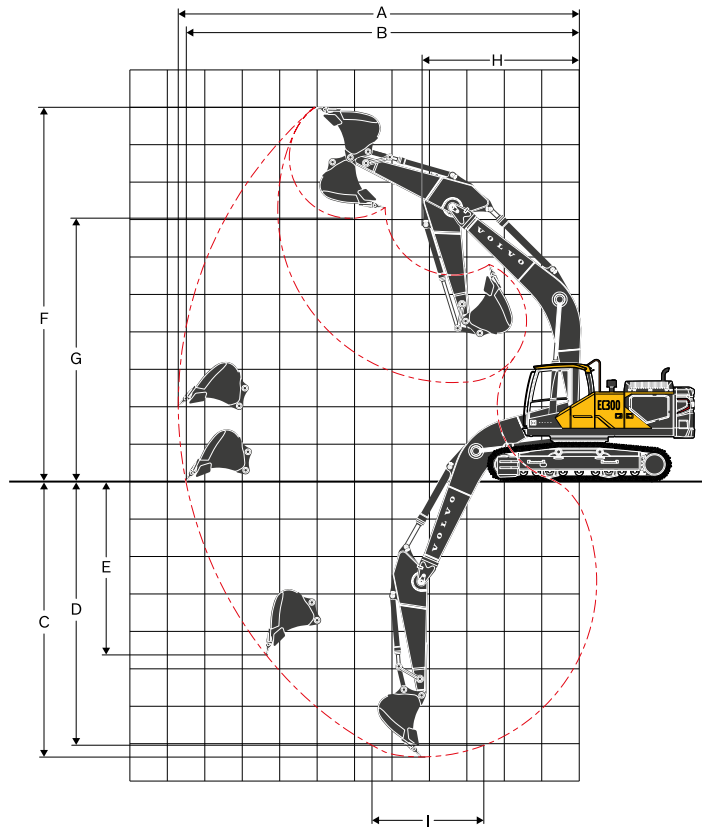

WORKING RANGES WITH DIRECT FIT BUCKET

Description	Unit	EC300F L		EC300F LR
Boom	m	6.2		10.2
Arm	m	2.55	3.05	7.9
A. Max. digging reach	mm	10 190	10 720	18 590
B. Max. digging reach on ground	mm	9 980	10 520	18 480
C. Max. digging depth	mm	6 850	7 350	14 750
D. Max. digging depth (l=2.44 m level)	mm	6 610	7 160	14 650
E. Max. vertical wall digging depth	mm	5 365	6 080	13 490
F. Max. cutting height	mm	9 560	9 990	14 940
G. Max. dumping height	mm	6 670	7 040	12 600
H. Min. front swing radius	mm	4 220	4 180	6 190

DIGGING FORCES WITH DIRECT FIT BUCKET

Breakout force (bucket)	Normal	SAE J1179	kN	165	165	69
	Power boost	SAE J1179	kN	179	179	-
	Normal	ISO 6015	kN	190	190	80
	Power boost	ISO 6015	kN	207	207	-
Tearout force (arm)	Normal	SAE J1179	kN	158	133	51
	Power boost	SAE J1179	kN	172	144	-
	Normal	ISO 6015	kN	163	136	52
	Power boost	ISO 6015	kN	177	148	-

Specifications

GROUND PRESSURE

EC300F L

Description	Shoe width	Operating weight	Ground pressure	Overall width	Operating weight	Ground pressure	Overall width
	mm	kg	kPa	mm	kg	kPa	mm
Triple grouser	600	30 730	59.3	3 190	30 660	59.2	3 190
	700	31 310	51.8	3 290	31 240	51.7	3 290
	800	32 050	46.4	3 390	31 980	46.3	3 390
Double grouser	600	31 100	60.0	3 190	31 030	59.9	3 190

**EC300F L, 6.2 m HD boom, 3.05 m HD arm,
1 387 kg bucket, 6 200 kg counterweight**

**EC300F L, 6.2 m HD boom, 2.55 m HD arm,
1 387 kg bucket, 6 200 kg counterweight**

Description	Shoe width	Operating weight	Ground pressure	Overall width
	mm	kg	kPa	mm
Triple grouser	600	30 940	59.7	3 190
	700	31 520	52.1	3 290
	800	32 260	46.7	3 390
Double grouser	600	31 310	60.4	3 190

**EC300F L, 6.2 m XD boom, 3.05 m XD arm,
1 387 kg bucket, 6 200 kg counterweight**

EC300F LR

Description	Shoe width	Operating weight	Ground pressure	Overall width
	mm	kg	kPa	mm
Triple grouser	600	31 390	60.6	3 190
	700	31 970	52.9	3 290
	800	32 710	47.3	3 390
Double grouser	600	31 760	61.3	3 190

**EC300F LR, 10.2 m LR boom, 7.9 m LR arm,
472 kg bucket, 6 900 kg counterweight**

BUCKET SELECTION GUIDE

EC300F L with 600 mm shoe, 6 200 kg counterweight

Bucket Type		Capacity	Cutting width	Weight	Recommended maximum material density (kg/m ³)		
					6.2 m HD Boom		6.2 m XD Boom
		L	mm	kg	2.55 m HD	3.05 m HD	3.05 m XD
V4	GP	550	600	883	1 800	1 800	1 800
		550	600	876	1 800	1 800	1 800
		660	750	867	1 800	1 800	1 800
		660	750	924	1 800	1 800	1 800
		770	900	986	1 800	1 800	1 800
		770	900	996	1 800	1 800	1 800
		950	1 090	1 025	1 800	1 800	1 800
		1 140	1 240	1 192	1 800	1 800	1 800
		1 140	1 240	1 153	1 800	1 800	1 800
		1 320	1 390	1 209	1 800	1 800	1 800
		1 320	1 390	1 273	1 800	1 800	1 800
		1 320	1 390	389	1 800	1 800	1 800
		1 450	1 490	1 315	1 800	1 800	1 800
		1 450	1 490	1 270	1 800	1 800	1 800
		1 500	1 500	1 354	1 800	1 800	1 800
		1 510	1 540	1 314	1 800	1 800	1 800
		1 510	1 540	1 371	1 800	1 800	1 800
		1 510	1 540	1 331	1 800	1 800	1 800
		1 510	1 540	1 325	1 800	1 800	1 800
		1 690	1 690	1 415	1 800	1 800	1 800
		1 690	1 690	1 408	1 800	1 800	1 800
		1 760	1 740	1 501	1 800	1 800	1 800
		1 760	1 740	1 448	1 800	1 800	1 800
		1 760	1 740	1 512	1 800	1 800	1 800
		1 760	1 740	1 466	1 800	1 800	1 800
		1 930	1 840	1 530	1 800	1 800	1 800
	2 060	1 950	1 590	1 800	1 500	1 500	
		FD	950	1 500	796	1 800	1 800
	1 030		1 600	834	1 800	1 800	1 800

For long reach boom and arm configuration, Volvo recommends to use 0.57 m³ (0.75 yd³) bucket. Please consult with your Volvo dealer for the proper match of buckets and attachments to suit the application.

The recommendations are given as a guide only, based on typical operation conditions.

Bucket capacity based on ISO 7451, heaped material with a 1:1 angle of repose.

Maximum material density

D: > 1 900 kg/m³: Wet mud, Iron ore

C: 1 700 ~ 1 800 kg/m³: Granite, Wet sand, Well blasted rock

B: 1 400 ~ 1 600 kg/m³: Wet earth and clay, Limestone, Sandstone

A: 1 200 ~ 1 300 kg/m³: Coal, Caliche, Shale

X: Not recommended

Specifications

BUCKET SELECTION GUIDE

EC300F L with 600 mm shoe, 6 200 kg counterweight

Bucket Type		Capacity	Cutting width	Weight	Recommended maximum material density (kg/m ³)		
					6.2 m HD Boom		6.2 m XD Boom
		L	mm	kg	2.55 m HD	3.05 m HD	3.05 m XD
V4	HD	550	600	881	2 100	2 100	2 100
		550	600	947	2 100	2 100	2 100
		660	750	931	2 100	2 100	2 100
		660	750	936	2 100	2 100	2 100
		660	750	996	2 100	2 100	2 100
		660	750	1 003	2 100	2 100	2 100
		1 140	1 240	1 280	2 100	2 100	2 100
		1 140	1 240	1 225	2 100	2 100	2 100
		1 140	1 240	1 235	2 100	2 100	2 100
		1 140	1 240	1 291	2 100	2 100	2 100
		1 140	1 240	1 302	2 100	2 100	2 100
		1 320	1 390	1 301	2 100	2 100	2 100
		1 320	1 390	1 311	2 100	2 100	2 100
		1 320	1 390	1 321	2 100	2 100	2 100
		1 320	1 390	1 377	2 100	2 100	2 100
		1 320	1 390	1 387	2 100	2 100	2 100
		1 510	1 540	1 387	2 100	2 100	2 100
		1 510	1 540	1 453	2 100	2 100	2 100
		1 510	1 540	1 478	2 100	2 100	2 100
		1 510	1 540	1 398	2 100	2 100	2 100
1 510	1 540	1 423	2 100	2 100	2 100		
1 510	1 540	1 463	2 100	2 100	2 100		
1 510	1 540	1 489	2 100	2 100	2 100		
1 690	1 690	1 485	2 100	2 100	1 800		
1 690	1 690	1 519	2 100	1 800	1 800		
1 690	1 690	1 551	2 100	1 800	1 800		
1 690	1 690	1 585	2 100	1 800	1 800		
1 930	1 840	1 626	1 800	1 600	1 600		
1 930	1 840	1 692	1 800	1 600	1 600		

EC300F LR with 800 mm shoe, 6 900 kg counterweight

Bucket Type		Capacity	Cutting width	Weight	Recommended maximum material density (kg/m ³)
					10.2 m Boom
		L	mm	kg	2.55 m
V4	GP	660	1 050	443	1 800
	FD	460	1 250	422	1 800

For long reach boom and arm configuration, Volvo recommends to use 0.57 m³ (0.75 yd³) bucket. Please consult with your Volvo dealer for the proper match of buckets and attachments to suit the application.

The recommendations are given as a guide only, based on typical operation conditions.

Bucket capacity based on ISO 7451, heaped material with a 1:1 angle of repose.

Maximum material density

D: > 1 900 kg/m³: Wet mud, Iron ore

C: 1 700 ~ 1 800 kg/m³: Granite, Wet sand, Well blasted rock

B: 1 400 ~ 1 600 kg/m³: Wet earth and clay, Limestone, Sandstone

A: 1 200 ~ 1 300 kg/m³: Coal, Caliche, Shale

X: Not recommended

LIFTING CAPACITY EC300F L

Lifting capacity at the arm end without bucket.

For lifting capacity including bucket, simply subtract actual weight of the direct fit bucket or the bucket with quick coupler from the following values.

	Lifting hook related to ground level	1.5 m		3.0 m		4.5 m		6.0 m		7.5 m		9.0 m		Max. reach		Max. m	
		Along UC	Across UC	Along UC	Across UC	Along UC	Across UC	Along UC	Across UC	Along UC	Across UC	Along UC	Across UC	Along UC	Across UC		
Boom : 6.2 m XD Arm : 2.55 m HD Shoe : 600 mm CWT : 6 200 kg	6 m	kg						*6 940	*6 940						*7 050	*7 050	6.78
	4.5 m	kg						*7 410	*7 410	*7 040	5 990				*7 050	5 700	7.72
	3 m	kg					*10 820	*10 820	*8 470	8 170	*7 410	5 840			*7 170	4 990	8.27
	1.5 m	kg					*13 520	11 490	*9 720	7 730	*8 010	5 630			*7 390	4 640	8.53
	0 m	kg					*15 080	10 910	*10 740	7 380	*8 560	5 440			7 640	4 550	8.52
	-1.5 m	kg					*15 350	10 740	*11 230	7 180	*8 850	5 320			7 960	4 710	8.23
	-3 m	kg			*14 280	*14 280	*14 780	10 770	*11 080	7 150	*8 580	5 320			*8 370	5 210	7.63
	-4.5 m	kg			*17 940	*17 940	*13 300	10 960	*10 000	7 270					*8 720	6 380	6.64
	-6 m	kg			*13 490	*13 490	*10 010	*10 010							*8 750	*8 750	5.03
Boom : 6.2 m HD Arm : 3.05 m HD Shoe : 600 mm CWT : 5 50000 kg	6 m	kg													*5 950	5 840	7.44
	4.5 m	kg						*6 620	*6 620	*6 320	5 730				*5 750	4 790	8.3
	3 m	kg					*9 540	*9 540	*7 680	*7 680	*6 790	5 540			*5 780	4 240	8.82
	1.5 m	kg					*12 220	11 000	*8 960	7 330	*7 440	5 300	6 400	4 000	*6 020	3 960	9.06
	0 m	kg					*14 130	10 270	*10 080	6 920	*8 070	5 080	6 300	3 900	6 250	3 870	9.05
	-1.5 m	kg			*6 230	*6 230	*14 830	9 970	*10 740	6 670	8 080	4 930			6 460	3 980	8.77
	-3 m	kg	*8 410	*8 410	*12 420	*12 420	*14 600	9 930	*10 830	6 590	8 030	4 880			7 080	4 340	8.22
	-4.5 m	kg	*14 410	*14 410	*18 890	*18 890	*13 510	10 070	*10 140	6 660					*7 850	5 150	7.31
	-6 m	kg			*15 150	*15 150	*11 070	10 430							*8 020	7 140	5.9
Boom : 6.2 m XD Arm : 3.705m XD Shoe : 600 mm CWT : 6 200 kg	6 m	kg													*5 870	5 540	7.44
	4.5 m	kg						*6 530	*6 530	*6 240	5 430				*5 670	4 530	8.3
	3 m	kg					*9 450	*9 450	*7 600	7 440	*6 710	5 250			*5 710	3 990	8.82
	1.5 m	kg					*12 150	10 500	*8 890	6 970	*7 370	5 020	6 040	3 760	*5 950	3 720	9.06
	0 m	kg					*14 080	9 790	*10 020	6 570	7 810	4 800	5 940	3 670	5 890	3 640	9.05
	-1.5 m	kg			*6 160	*6 160	*14 790	9 510	10 690	6 330	7 650	4 660			6 100	3 750	8.77
	-3 m	kg	*8 330	*8 330	*12 340	*12 340	*14 580	9 480	10 600	6 260	7 600	4 610			6 690	4 100	8.22
	-4.5 m	kg	*14 330	*14 330	*18 910	*18 910	*13 490	9 630	*10 110	6 340					*7 810	4 880	7.31
	-6 m	kg			*15 170	*15 170	*11 050	9 990							*7 990	6 820	5.9

Notes: 1. Machine in "Fine Mode-F" (Power Boost) for lifting capacities. 2. The above loads are in compliance with SAE J1097 and ISO 10567 Hydraulic Excavator Lifting Capacity Standards. 3. Rated loads do not exceed 87% of hydraulic lifting capacity or 75% of tipping load. 4. Rated loads marked with an asterisk (*) are limited by hydraulic capacity rather than tipping load.



VOLVO

EC3

VOLVO



Equipment

STANDARD AND OPTIONAL EQUIPMENT

• = Standard / o = Optional

Engine

Turbocharged, 4 stroke diesel engine with water cooling, direct injection and charged air cooler that meets T3 requirements	•
Cooling system by Direct Fan	•
Cooling system by Hydraulic Fan	o
Air filter, High efficiency	o
Air intake heater	•
Cyclone pre-cleaner	•
Fuel shut off valve	•
Engine block heater	o
Coolant heater by diesel	o
Precleaner, oil bath	o
Delayed engine Shutdown	•
Automatic engine shutdown	•
Water separator with heater	o
Fuel filter and water separator	•

Electric / Electronic control system

Anti-theft with code lock system	•
Automatic idling system	•
Standard light	•
Extra light	o
Master electrical disconnect switch	•
Engine restart prevention circuit	•

Undercarriage and structures

3-point side access	•
Guardrail, fixed/foldable	o
Lower frame,LC	o
Lower frame,STD	o
Link 600 / 700 / 800 mm triple grouser shoe	o
Link 600 mm double grouser shoe	o
Dual toolbox	•
Undercover STD / HD	o

STANDARD AND OPTIONAL EQUIPMENT

• = Standard / o = Optional

Hydraulic system

EH (Electro-Hydraulic) control system	•
One touch power boost	•
Priority Adjustment	•
Boom down speed control	•
Shock reduction function	•
Joystick, Semi-long / 4 switch / 4 switch & 1 proportional / Simple L8 / L8	o
Hydraulic oil mineral 32 / 46 / 68	o
Longlife hyd oil mineral 32 / 46 / 68	o
Pattern change	•
Boom float function	o
Comfort driving control	o
Dedicated drain line	o
Hose rupture valve for boom	o
Hose rupture valve for arm	o

Cab and interior

ROPS certified cab	•
FOG (Falling Object Guard)	o
FOPS (Falling Object Protection Structure)	o
8» HD display	•
Mechanical sus/Air sus seat	o
Seat belt, 2 inch 2 point / 3 inch 2 point / 3 inch 3 point	o
Front rain shield	o
Sun screens, front, roof, rear	•
Lower wiper	o
Sun shield, roof hatch	o
Safety net	o
Travel pedals and hand levers	•
Adjustable operator seat and joystick control console	•
Heater & air-conditioner, automatic	•
air-conditioner, automatic	o
AM / FM / USB / Bluetooth stereo with Keypad	•
Large storage area	•
Pull-up type front window	•
Removable lower windshield	•

STANDARD AND OPTIONAL EQUIPMENT

• = Standard / o = Optional

Digging equipment

Boom: 6.2 m monoblock	o
Arm: 3.05 m	o
Arm: 2.55 m	o

Machine controls

Kinematic sensor package	o
Volvo Co-Pilot 2nd display, 12.8» touchable Full HD	o
Dig Assist, Start	o
Dig Assist, 2D	o
Dig Assist, In-Field Design	o
Dig Assist, Topcon 3D-MC	o
Dig Assist, Infield-Design Advanced	o
Dig Assist, On-Board Weighing	o
Dig Assist, Laser Receiver	o
Volvo Active Control	o
Dig Assist, Boundary Limit	o

Service and maintenance

Swing out A/C condenser	•
Fuel filler pump	o
Jump start connector	o
Tool kit	o

Safety and security

Travel alarm, beep / white noise	o
Flashing beacon, LED	o
Rear view camera	o
Side view camera	o
HD VSV (Volvo Smart View)	o

Not all products are available in all markets. Under our policy of continuous improvement, we reserve the right to change specifications and design without prior notice. The illustrations do not necessarily show the standard version of the machine.

V O L V O